



# KISUMU CENTRAL NATIONAL GOVERNMENT CONSTITUENCY DEVELOPMENT FUND

Proposed Construction to Completion of 45 capacity Science  
Laboratory

at

St. Peter's Nanga Secondary School

TENDER NO: KSMCTRL/NGCDF/CSDU/EDU/NNGA/1/2023/24

## TENDER DOCUMENT

PROJECT MANAGER  
DEPARTMENT OF PUBLIC WORKS  
P.O. BOX 821 - 40100  
KISUMU

ISSUE DATE	JULY 15, 2024
TENDER SUBMISSION DATE	JULY 25, 2024

## **INVITATION TO TENDER**

Procuring Entity **Kisumu Central National Government Constituency Development Fund**  
Tender Name **Proposed Construction to Completion of 45 capacity Science Laboratory at St. Peter's Nanga Secondary School**  
Tender No **KSMCTRL/NGCDF/CSDU/EDU/NNGA/1/2023/24**

The **Kisumu Central National Government Constituency Development Fund** invites sealed tenders for the construction of **Proposed Construction to Completion of a 45 capacity Science Laboratory at St. Peter's Nanga Secondary School**

Tendering will be conducted under open competitive method (National) using a standardized tender document. Tendering is **OPEN to all eligible bidders**

Qualified and interested tenderers may obtain further information and inspect the Tender Documents during office hours **Monday to Friday Between. 0900 to 1600 hours** at the address given below.

A complete set of tender documents may be purchased or obtained by interested tenders upon payment of a non-refundable fees of **Ksh 1,000 (One Thousand Five Hundred)** in Banker's Cheque and payable to **KISUMU CENTRAL NATIONAL GOVERNMENT CONSTITUENCY DEVELOPMENT FUND**. Tender documents may also be obtained electronically from the Website(s) [www.ngcdf.go.ke](http://www.ngcdf.go.ke) Tender documents obtained electronically will be **FREE OF CHARGE**.

Tender documents may be viewed and downloaded for free from the website(s)[www.ngcdf.go.ke](http://www.ngcdf.go.ke) Tenderers who download the tender document must forward their particulars immediately [cdfkisumucentral@ngcdf.go.ke](mailto:cdfkisumucentral@ngcdf.go.ke), P.O Box 1077-40100 Kisumu to facilitate any further clarification or addendum.

Tenders shall be quoted be in Kenya Shillings and shall include all taxes. Tenders shall remain valid for 120 days from the date of opening of tenders.

All Tenders must be accompanied by a tender security of **Kshs. 80,000.00** valid for 120 days from the date of tender opening.

The Tenderer shall chronologically **SERIALIZE ALL PAGES** of the tender documents submitted.

Completed tenders must be delivered to the address below on or before **11.00 AM, JULY 25, 2024**.  
*Electronic* Tenders **WILL NOT** be permitted.

Tenders will be opened immediately after the deadline date and time specified above or any dead line date and times specified later. Tenders will be publicly opened in the presence of the 'Tenderers' designated representatives who choose to attend at the address below.

Late tenders will be rejected.

The addresses referred to above are:

Address for obtaining further information and for purchasing tender documents/ Submission and Opening of Tenders

### **FUND ACCOUNT MANAGER**

Kisumu Central National Government Constituency Development Fund  
At DCC Kisumu Central Headquarter  
P.O Box 1077-40100 Kisumu,  
[cdfkisumucentral@ngcdf.go.ke](mailto:cdfkisumucentral@ngcdf.go.ke)

---

## **PART 1 - TENDERING PROCEDURES**

---

## SECTION I: INSTRUCTIONS TO TENDERERS

### General Provisions

#### Scope of Tender

1.1. The Procuring Entity as defined in the Appendix to Conditions of Contract invites tenders for Works Contract as described in the tender documents. The name, identification, and number of lots (contracts) of this Tender Document are **specified in the TDS**.

#### Fraud and Corruption

The Procuring Entity requires compliance with the provisions of the Public Procurement and Asset Disposal Act, 2015, Section 62 “Declaration not to engage in corruption”. The tender submitted by a person shall include a declaration that the person shall not engage in any corrupt or fraudulent practice and a declaration that the person or his or her sub-contractors are not debarred from participating in public procurement proceedings.

The Procuring Entity requires compliance with the provisions of the Competition Act 2010, regarding collusive practices in contracting. Any tenderer found to have engaged in collusive conduct shall be disqualified and criminal and/or civil sanctions may be imposed. To this effect, Tenders shall be required to complete and sign the “Certificate of Independent Tender Determination” annexed to the Form of Tender.

Unfair Competitive Advantage - Fairness and transparency in the tender process require that the firms or their Affiliates competing for a specific assignment do not derive a competitive advantage from having provided consulting services related to this tender. To that end, the Procuring Entity shall indicate in the **Data Sheet** and make available to all the firms together with this tender document all information that would in that respect give such firm any unfair competitive advantage over competing firms.

Unfair Competitive Advantage - Fairness and transparency in the tender process require that the Firms or their Affiliates competing for a specific assignment do not derive a competitive advantage from having provided consulting services related to this tender being tendered for. The Procuring Entity shall indicate in the **TDS** firms (if any) that provided consulting services for the contract being tendered for. The Procuring Entity shall check whether the owners or controllers of the Tenderer are same as those that provided consulting services. The Procuring Entity shall, upon request, make available to any tenderer information that would give such firm unfair competitive advantage over competing firms.

#### Eligible Tenderers

A Tenderer may be a firm that is a private entity, a state-owned enterprise or institution subject to IIT 3.7 or any combination of such entities in the form of a joint venture (JV) under an existing agreement or with the intent to enter into such an agreement supported by a letter of intent. Public employees and their close relatives (*spouses, children, brothers, sisters and uncles and aunts*) are not eligible to participate in the tender. In the case of a joint venture, all members shall be jointly and severally liable for the execution of the entire Contract in accordance with the Contract terms. The JV shall nominate a Representative who shall have the authority to conduct all business for and on behalf of any and all the members of the JV during the tendering process and, in the event the JV is awarded the Contract, during contract execution. The maximum number of JV members shall be specified in the **TDS**.

Public Officers of the Procuring Entity, their Spouses, Child, Parent, Brothers or Sister. Child, Parent, Brother or Sister of a Spouse, their business associates or agents and firms/organizations in which they have a substantial or controlling interest shall not be eligible to tender or be awarded a contract. Public Officers are also not allowed to participate in any procurement proceedings.

A Tenderer shall not have a conflict of interest. Any tenderer found to have a conflict of interest shall be disqualified. A tenderer may be considered to have a conflict of interest for the purpose of this tendering process, if the tenderer:

Directly or indirectly controls, is controlled by or is under common control with another tenderer; or  
Receives or has received any direct or indirect subsidy from another tenderer; or  
Has the same legal representative as another tenderer; or Has a relationship with another tenderer, directly or through common third parties, that puts it in a position to influence the tender of another tenderer, or influence the decisions of the Procuring Entity regarding this tendering process; or

Any of its affiliates participated as a consultant in the preparation of the design or technical specifications of the works that are the subject of the tender; or

any of its affiliates has been hired (or is proposed to be hired) by the Procuring Entity as Engineer for the Contract implementation; or

Would be providing goods, works, or non-consulting services resulting from or directly related to consulting services for the preparation or implementation of the contract specified in this Tender Document or Has a close business or family relationship with a professional staff of the Procuring Entity who:

are directly or indirectly involved in the preparation of the Tender document or specifications of the Contract, and/or the Tender evaluation process of such contract; or  
would be involved in the implementation or supervision of such Contract unless the conflict stemming from such relationship has been resolved in a manner acceptable to the Procuring Entity throughout the tendering process and execution of the Contract.

A tenderer shall not be involved in corrupt, coercive, obstructive, collusive or fraudulent practice. A tenderer that is proven to have been involved any of these practices shall be automatically disqualified.

A Tenderer (either individually or as a JV member) shall not participate in more than one Tender, except for permitted alternative tenders. This includes participation as a subcontractor in other Tenders. Such participation shall result in the disqualification of all Tenders in which the firm is involved. A firm that is not a tenderer or a JV member may participate as a subcontractor in more than one tender. Members of a joint venture may not also make an individual tender, be a subcontractor in a separate tender or be part of another joint venture for the purposes of the same Tender.

A Tenderer may have the nationality of any country, subject to the restrictions pursuant to ITT 4.8. A Tenderer shall be deemed to have the nationality of a country if the Tenderer is constituted, incorporated or registered in and operates in conformity with the provisions of the laws of that country, as evidenced by its articles of incorporation (or equivalent documents of constitution or association) and its registration documents, as the case may be. This criterion also shall apply to the determination of the nationality of proposed subcontractors or sub-consultants for any part of the Contract including related Services.

Tenderer that has been debarred from participating in public procurement shall be ineligible to tender or be awarded a contract. The list of debarred firms and individuals is available from the website of PPRA [www.ppra.go.ke](http://www.ppra.go.ke)

Tenderers that are state-owned enterprises or institutions may be eligible to compete and be awarded a Contract(s) only if they are accredited by PPRA to be (i) a legal public entity of the state Government and/or public administration, (ii) financially autonomous and not receiving any significant subsidies or budget support from any public entity or Government, and (iii) operating under commercial law and vested with legal rights and liabilities similar to any commercial enterprise to enable it compete with firms in the private sector on an equal basis.

A Firms and individuals may be ineligible if their countries of origin (a) as a matter of law or official regulations, Kenya prohibits commercial relations with that country, or (b) by an act of compliance with a decision of the United Nations Security Council taken under Chapter VII of the Charter of the United Nations, Kenya prohibits any import of goods or contracting of works or services from that country, or any payments to any country, person, or entity in that country. A tenderer shall provide such documentary evidence of eligibility satisfactory to the Procuring Entity, as the Procuring Entity shall reasonably request

Foreign tenderers are required to source at least forty (40%) percent of their contract inputs (in supplies, subcontracts and labor) from national suppliers and contractors. To this end, a foreign tenderer shall provide in its tender documentary evidence that this requirement is met. Foreign tenderers not meeting this criterion will be automatically disqualified. Information required to enable the Procuring Entity determine if this condition is met shall be provided in for this purpose is be provided in

***“SECTION III - EVALUATION AND QUALIFICATION CRITERIA, Item 9”.***

Pursuant to the eligibility requirements of ITT 4.10, a tender is considered a foreign tenderer, if the tenderer is not registered in Kenya or if the tenderer is registered in Kenya and has less than 51 percent ownership by Kenyan Citizens. JVs are considered as foreign tenderers if the individual member firms are not registered in Kenya or if are registered in Kenya and have less than 51 percent ownership by Kenyan citizens. The JV shall not subcontract to foreign firms more than 10 percent of the contract price, excluding provisional sums.

The National Construction Authority Act of Kenya requires that all local and foreign contractors be registered with the National Construction Authority and be issued with a Registration Certificate before they can undertake any construction works in Kenya. Registration shall not be a condition for tender, but it shall be a condition of contract award and signature. A selected tenderer shall be given opportunity to register before such award and signature of contract. Application for registration with National Construction Authority may be accessed from the website [www.nca.go.ke](http://www.nca.go.ke).

The Competition Act of Kenya requires that firms wishing to tender as Joint Venture undertakings which may prevent, distort or lessen competition in provision of services are prohibited unless they are exempt in accordance with the provisions of Section 25 of the Competition Act, 2010. JVs will be required to seek for exemption from the Competition Authority. Exemption shall not be a condition for tender, but it shall be a condition of contract award and signature. A JV tenderer shall be given opportunity to seek such exemption as a condition of award and signature of contract. Application for exemption from the Competition Authority of Kenya may be accessed from the website [www.cak.go.ke](http://www.cak.go.ke)

A Kenyan tenderer shall provide evidence of having fulfilled his/her tax obligations by producing a valid tax clearance certificate or tax exemption certificate issued by the Kenya Revenue Authority.

## **Eligible Goods, Equipment, and Services**

Goods, equipment and services to be supplied under the Contract may have their origin in any country that is not eligible under ITT 3.9. At the Procuring Entity's request, Tenderers may be required to provide evidence of the origin of Goods, equipment and services.

Any goods, works and production processes with characteristics that have been declared by the relevant national environmental protection agency or by other competent authority as harmful to human beings and to the environment shall not be eligible for procurement.

## **Tenderer's Responsibilities**

The tenderer shall bear all costs associated with the preparation and submission of his/her tender, and the Procuring Entity will in no case be responsible or liable for those costs.

The tenderer, at the tenderer's own responsibility and risk, is encouraged to visit and examine the Site of the Works and its surroundings, and obtain all information that may be necessary for preparing the tender and entering into a contract for construction of the Works. The costs of visiting the Site shall be at the tenderer's own expense.

The Tenderer and any of its personnel or agents will be granted permission by the Procuring Entity to enter upon its premises and lands for the purpose of such visit. The Tenderer shall indemnify the Procuring Entity against all liability arising from death or personal injury, loss of or damage to property, and any other losses and expenses incurred as a result of the inspection.

The tenderer shall provide in the Form of Tender and Qualification Information, a preliminary description of the proposed work method and schedule, including charts, as necessary or required.

## **Contents of Tender Documents**

### **Sections of Tender Document**

The tender document consists of Parts 1, 2, and 3, which includes all the sections specified below, and which should be read in conjunction with any Addenda issued in accordance with ITT 8.

#### **PART 1 Tendering Procedures**

Section I - Instructions to Tenderers (ITT) Section II -

Tender Data Sheet (TDS)

Section III - Evaluation and Qualification Criteria Section IV -

Tendering Forms

#### **PART 2 Works Requirements Section**

V - Drawings Section VI - Specifications

Section VII - Bills of Quantities

#### **PART 3 Conditions of Contract and Contract Forms Section**

VIII - General Conditions of Contract (GCC) Section IX - Special

Conditions of Contract (SC) Section X - Contract Forms

The Invitation to Tender Document (ITT) issued by the Procuring Entity is not part of the Contract documents.

Unless obtained directly from the Procuring Entity, the Procuring Entity is not responsible for the completeness of the Tender document, responses to requests for clarification, the minutes of the pre-Tender meeting (if any), or Addenda to the Tender document in accordance with ITT 8. In case of any contradiction, documents obtained directly from the Procuring Entity shall prevail.

The Tenderer is expected to examine all instructions, forms, terms, and specifications in the Tender Document and to furnish with its Tender all information and documentation as is required by the Tender document.

### **Site Visit**

7.1 The Tenderer, at the Tenderer's own responsibility and risk, is encouraged to visit and examine and inspect the Site of the Required Services and its surroundings and obtain all information that may be necessary for preparing the Tender and entering into a contract for the Services. The costs of visiting the Site shall be at the Tenderer's own expense.

### **Pre-Tender Meeting**

The Procuring Entity shall specify in the TDS if a pre-tender meeting will be held, when and where. The Procuring Entity shall also specify in the TDS if a pre-arranged pretender site visit will be held and when. The Tenderer's designated representative is invited to attend a pre-arranged pretender visit of the site of the works. The purpose of the meeting will be to clarify issues and to answer questions on any matter that may be raised at that stage.

The Tenderer is requested to submit any questions in writing, to reach the Procuring Entity not later than the period specified in the TDS before the meeting.

Minutes of the pre-Tender meeting and the pre-arranged pretender site visit of the site of the works, if applicable, including the text of the questions asked by Tenderers and the responses given, together with any responses prepared after the meeting, will be transmitted promptly to all Tenderers who have acquired the Tender Documents in accordance with ITT 6.3. Minutes shall not identify the source of the questions asked.

The Procuring Entity shall also promptly publish anonym zed (*no names*) Minutes of the pre-Tender meeting and the pre-arranged pretender visit of the site of the works at the web page identified in the TDS. Any modification to the Tender Documents that may become necessary as a result of the pre-tender meeting and the pre-arranged pretender site visit, shall be made by the Procuring Entity exclusively through the issue of an Addendum pursuant to ITT 8 and not through the minutes of the pre-Tender meeting. Nonattendance at the pre-Tender meeting will not be a cause for disqualification of Tenderer.

### **Clarification and amendments of Tender Documents**

9.1 A Tenderer requiring any clarification of the Tender Document shall contact the Procuring Entity in writing at the Procuring Entity's address specified in the TDS or raise its enquiries during the pre- Tender meeting and the pre- arranged pretender visit of the site of the works if provided for in accordance with ITT 8.4. The Procuring Entity will respond in writing to any request for clarification, provided that such request is received no later than the period specified in the TDS prior to the deadline for submission of tenders. The Procuring Entity shall forward copies of its response to all tenderers who have acquired the Tender Documents in accordance with ITT 6.3, including a description of the inquiry but without identifying its source. If specified in the TDS, the Procuring Entity shall also promptly publish its response at the web page identified in the TDS. Should the clarification result in changes to the essential elements of the Tender Documents, the Procuring Entity shall amend the Tender Documents appropriately following the procedure under ITT 8.4.

### **Amendment of Tendering Document**

At any time prior to the deadline for submission of Tenders, the Procuring Entity may amend the Tendering document by issuing addenda.

Any addendum issued shall be part of the tendering document and shall be communicated in writing to all who have obtained the tendering document from the Procuring Entity in accordance with ITT

6.3. The Procuring Entity shall also promptly publish the addendum on the Procuring Entity's web page in accordance with ITT 8.4.

To give prospective Tenderers reasonable time in which to take an addendum into account in preparing their Tenders, the Procuring Entity shall extend, as necessary, the deadline for submission of Tenders, in accordance with ITT 25.2 below.

## **C. Preparation of Tenders**

### **Cost of Tendering**

11.1 The Tenderer shall bear all costs associated with the preparation and submission of its Tender, and the Procuring Entity shall not be responsible or liable for those costs, regardless of the conduct or outcome of the tendering process.

### **Language of Tender**

The Tender, as well as all correspondence and documents relating to the tender exchanged by the tenderer and the Procuring Entity, shall be written in the English Language. Supporting documents and printed literature that are part of the Tender may be in another language provided they are accompanied by an accurate and notarized translation of the relevant passages into the English Language, in which case, for purposes of interpretation of the Tender, such translation shall govern.

## **Documents Comprising the Tender**

The Tender shall comprise the following:

Form of Tender prepared in accordance with ITT 14;

Schedules including priced Bill of Quantities, completed in accordance with ITT14 and 1

Tender Security or Tender-Securing Declaration, in accordance with ITT 21.1;

Alternative Tender, if permissible, in accordance with ITT 15;

Authorization: written confirmation authorizing the signatory of the Tender to commit the Tenderer, in accordance with ITT 22.3;

Qualifications: documentary evidence in accordance with ITT 19 establishing the Tenderer's qualifications to perform the Contract if its Tender is accepted;

Conformity: a technical proposal in accordance with ITT 18;

Any other document required in the TDS.

In addition to the requirements under ITT 11.1, Tenders submitted by a JV shall include a copy of the Joint Venture Agreement entered into by all members. Alternatively, a letter of intent to execute a Joint Venture Agreement in the event of a successful Tender shall be signed by all members and submitted with the Tender, together with a copy of the proposed Agreement. The Tenderer shall chronologically serialize pages of all tender documents submitted.

The Tenderer shall furnish in the Form of Tender information on commissions and gratuities, if any, paid or to be paid to agents or any other party relating to this Tender.

## **Form of Tender and Schedules**

The Form of Tender and Schedules, including the Bill of Quantities, shall be prepared using the relevant forms furnished in Section IV, Tendering Forms. The forms must be completed without any alterations to the text, and no substitutes shall be accepted except as provided under ITT 20.3. All blank spaces shall be filled in with the information requested.

## **Alternative Tenders**

Unless otherwise specified in the TDS, alternative Tenders shall not be considered.

When alternative times for completion are explicitly invited, a statement to that effect will be included in the TDS, and the method of evaluating different alternative times for completion will be described in Section III, Evaluation and Qualification Criteria.

Except as provided under ITT 13.4 below, Tenderers wishing to offer technical alternatives to the requirements of the Tender Documents must first price the Procuring Entity's design as described in the Tender Documents and shall further provide all information necessary for a complete evaluation of the alternative by the Procuring Entity, including drawings, design calculations, technical specifications, breakdown of prices, and proposed construction methodology and other relevant details. Only the technical alternatives, if any, of the Tenderer with the Winning Tender conforming to the basic technical requirements shall be considered by the Procuring Entity. When specified in the TDS, Tenderers are permitted to submit alternative technical solutions for specified parts of the Works, and such parts will be identified in the TDS, as will the method for their evaluating, and described in Section VII, Works' Requirements.

## **Tender Prices and Discounts**

The prices and discounts (including any price reduction) quoted by the Tenderer in the Form of Tender and in the Bill of Quantities shall conform to the requirements specified below.

The Tenderer shall fill in rates and prices for all items of the Works described in the Bill of Quantities. Items against which no rate or price is entered by the Tenderer shall be deemed covered by the rates for other items in the Bill of Quantities and will not be paid for separately by the Procuring Entity. An item not listed in the priced Bill of Quantities shall be assumed to be not included in the Tender, and provided that the Tender is determined substantially responsive notwithstanding this omission, the average price of the item quoted by substantially responsive Tenderers will be added to the Tender price and the equivalent total cost of the Tender so determined will be used for price comparison.

The price to be quoted in the Form of Tender, in accordance with ITT 14.1, shall be the total price of the Tender, including any discounts offered.

The Tenderer shall quote any discounts and the methodology for their application in the Form of Tender, in accordance with ITT 14.1.

It will be specified in the TDS if the rates and prices quoted by the Tenderer are or are not subject to adjustment during the performance of the Contract in accordance with the provisions of the Conditions of Contract, except in cases where the contract is subject to fluctuations and adjustments, not fixed price. In such a case, the Tenderer shall furnish the indices and weightings for the price adjustment formulae in the Schedule of Adjustment Data and the Procuring Entity may require the Tenderer to justify its proposed indices and weightings.

Where tenders are being invited for individual lots (contracts) or for any combination of lots (packages), tenderers wishing to offer discounts for the award of more than one Contract shall specify in their Tender the price reductions applicable to each package, or alternatively, to individual Contracts within the package. Discounts shall be submitted in accordance with ITT 16.4, provided the Tenders for all lots (contracts) are opened at the same time.

All duties, taxes, and other levies payable by the Contractor under the Contract, or for any other cause, as of the date 30 days prior to the deadline for submission of Tenders, shall be included in the rates and prices and the total Tender Price submitted by the Tenderer.

### **Currencies of Tender and Payment**

Tenderers shall quote entirely in Kenya Shillings. The unit rates and the prices shall be quoted by the Tenderer in the Bill of Quantities, entirely in Kenya shillings. A Tenderer expecting to incur expenditures in other currencies for inputs to the Works supplied from outside Kenya shall devise own ways of getting foreign currency to meet those expenditures.

### **Documents Comprising the Technical Proposal**

18.1 The Tenderer shall furnish a technical proposal including a statement of work methods, equipment, personnel, schedule and any other information as stipulated in Section IV, Tender Forms, in sufficient detail to demonstrate the adequacy of the Tenderer's proposal to meet the work's requirements and the completion time.

### **Documents Establishing the Eligibility and Qualifications of the Tenderer**

Tenderers shall complete the Form of Tender, included in Section IV, Tender Forms, to establish Tenderer's eligibility in accordance with ITT 4.

In accordance with Section III, Evaluation and Qualification Criteria, to establish its qualifications to perform the Contract the Tenderer shall provide the information requested in the corresponding information sheets included in Section IV, Tender Forms.

A margin of preference will not be allowed. Preference and reservations will be allowed, individually or in joint ventures. Applying for eligibility for Preference and reservations shall supply all information required to satisfy the criteria for eligibility specified in accordance with ITT 33.1.

Tenderers shall be asked to provide, as part of the data for qualification, such information, including details of ownership, as shall be required to determine whether, according to the classification established by the Procuring Entity, a contractor or group of contractors qualifies for a margin of preference. Further the information will enable the Procuring Entity identify any actual or potential conflict of interest in relation to the procurement and/or contract management processes, or a possibility of collusion between tenderers, and thereby help to prevent any corrupt influence in relation to the procurement process or contract management.

The purpose of the information described in ITT 19.4 above overrides any claims to confidentiality which a tenderer may have. There can be no circumstances in which it would be justified for a tenderer to keep information relating to its ownership and control confidential where it is tendering to undertake public sector work and receive public sector funds. Thus, confidentiality will not be accepted by the Procuring Entity as a justification for a Tenderer's failure to disclose, or failure to provide required information on its ownership and control.

The Tenderer shall provide further documentary proof, information or authorizations that the Procuring Entity may request in relation to ownership and control which information on any changes to the information which was provided by the tenderer under ITT 6.3. The obligations to require this information shall continue for the duration of the procurement process and contract performance and after completion of the contract, if any change to the information previously provided may reveal a conflict of interest in relation to the award or management of the contract.

All information provided by the tenderer pursuant to these requirements must be complete, current and accurate as at the date of provision to the Procuring Entity. In submitting the information required pursuant to these requirements, the Tenderer shall warrant that the information submitted is complete, current and accurate as at the date of submission to the Procuring Entity.

If a tenderer fails to submit the information required by these requirements, its tender will be rejected. Similarly, if the Procuring Entity is unable, after taking reasonable steps, to verify to a reasonable degree the information submitted by a tenderer pursuant to these requirements, then the tender will be rejected.

If information submitted by a tenderer pursuant to these requirements, or obtained by the Procuring Entity (whether through its own enquiries, through notification by the public or otherwise), shows any conflict of interest which could materially and improperly benefit the tenderer in relation to the procurement or contract management process, then: if the procurement process is still ongoing, the tenderer will be disqualified from the procurement process, if the contract has been awarded to that tenderer, the contract award will be set aside, the tenderer will be referred to the relevant law enforcement authorities for investigation of whether the tenderer or any other persons have committed any criminal offence.

If a tenderer submits information pursuant to these requirements that is incomplete, inaccurate or out-of-date, or attempts to obstruct the verification process, then the consequences ITT 6.7 will ensue unless the tenderer can show to the reasonable satisfaction of the Procuring Entity that any such act was not material, or was due to genuine error which was not attributable to the intentional act, negligence or recklessness of the tenderer.

### **Period of Validity of Tenders**

Tenders shall remain valid for the Tender Validity period specified in the TDS. The Tender Validity period starts from the date fixed for the Tender submission deadline (as prescribed by the Procuring Entity in accordance with ITT 24). A Tender valid for a shorter period shall be rejected by the Procuring Entity as non-responsive.

In exceptional circumstances, prior to the expiration of the Tender validity period, the Procuring Entity may request Tenderers to extend the period of validity of their Tenders. The request and the responses shall be made in writing. If a Tender Security is requested in accordance with ITT 21.1, it shall also be extended for thirty (30) days beyond the deadline of the extended validity period. A Tenderer may refuse the request without forfeiting its Tender security. A Tenderer granting the request shall not be required or permitted to modify its Tender, except as provided in ITT 20.3

If the award is delayed by a period exceeding the number of days to be specified in the TDS days beyond the expiry of the initial tender validity period, the Contract price shall be determined as follows:

in the case of **fixed price** contracts, the Contract price shall be the tender price adjusted by the factor specified in the **TDS**;

in the case of **adjustable price** contracts, no adjustment shall be made; or in any case, tender evaluation shall be based on the tender price without taking into consideration the applicable correction from those indicated above.

## **Tender Security**

The Tenderer shall furnish as part of its Tender, either a Tender-Securing Declaration or a Tender Security as specified in the TDS, in original form and, in the case of a Tender Security, in the amount and currency specified in the TDS. A Tender-Securing Declaration shall use the form included in Section IV, Tender Forms.

If a Tender Security is specified pursuant to ITT 19.1, the Tender Security shall be a demand guarantee in any of the following forms at the Tenderer's option: an unconditional Bank Guarantee issued by reputable commercial bank); or an irrevocable letter of credit; a Banker's cheque issued by a reputable commercial bank; or another security specified **in the TDS**,

If an unconditional bank guarantee is issued by a bank located outside Kenya, the issuing bank shall have a correspondent bank located in Kenya to make it enforceable. The Tender Security shall be valid for thirty (30) days beyond the original validity period of the Tender, or beyond any period of extension if requested under ITT 20.2.

If a Tender Security or Tender-Securing Declaration is specified pursuant to ITT 19.1, any Tender not accompanied by a substantially responsive Tender Security or Tender-Securing Declaration shall be rejected by the Procuring Entity as non-responsive.

If a Tender Security is specified pursuant to ITT 21.1, the Tender Security of unsuccessful Tenderers shall be returned as promptly as possible upon the successful Tenderer's signing the Contract and furnishing the Performance Security and any other documents required in the TDS. The Procuring Entity shall also promptly return the tender security to the tenderers where the procurement proceedings are terminated, all tenders were determined nonresponsive or a bidder declines to extend tender validity period.

The Tender Security of the successful Tenderer shall be returned as promptly as possible once the successful Tenderer has signed the Contract and furnished the required Performance Security, and any other documents required in the TDS.

The Tender Security may be forfeited or the Tender-Securing Declaration executed: if a Tenderer withdraws its Tender during the period of Tender validity specified by the Tenderer on the Form of Tender, or any extension thereto provided by the Tenderer; or if the successful Tenderer fails to: sign the Contract in accordance with ITT 50; or furnish a Performance Security and if required in the TDS, and any other documents required in the TDS.

Where tender securing declaration is executed, the Procuring Entity shall recommend to the PPRA that PPRA debars the Tenderer from participating in public procurement as provided in the law.

The Tender Security or the Tender-Securing Declaration of a JV shall be in the name of the JV that submits the Tender. If the JV has not been legally constituted into a legally enforceable JV at the time of tendering, the Tender Security or the Tender-Securing Declaration shall be in the names of all future members as named in the letter of intent referred to in ITT 4.1 and ITT 11.2.

A tenderer shall not issue a tender security to guarantee itself.

## **Format and Signing of Tender**

The Tenderer shall prepare one original of the documents comprising the Tender as described in ITT 13 and clearly mark it "ORIGINAL." Alternative Tenders, if permitted in accordance with ITT 15, shall be clearly marked "ALTERNATIVE." In addition, the Tenderer shall submit copies of the Tender, in the number specified in the TDS and clearly mark them "COPY." In the event of any discrepancy between the original and the copies, the original shall prevail.

Tenderers shall mark as “CONFIDENTIAL” all information in their Tenders which is confidential to their business. This may include proprietary information, trade secrets, or commercial or financially sensitive information.

The original and all copies of the Tender shall be typed or written in indelible ink and shall be signed by a person duly authorized to sign on behalf of the Tenderer. This authorization shall consist of a written confirmation as specified in the TDS and shall be attached to the Tender. The name and position held by each person signing the authorization must be typed or printed below the signature. All pages of the Tender where entries or amendments have been made shall be signed or initialed by the person signing the Tender.

In case the Tenderer is a JV, the Tender shall be signed by an authorized representative of the JV on behalf of the JV, and to be legally binding on all the members as evidenced by a power of attorney signed by their legally authorized representatives.

Any inter-lineation, erasures, or overwriting shall be valid only if they are signed or initialed by the person signing the Tender.

**D. Submission and Opening of  
Tenders Sealing and Marking of  
Tenders**

Depending on the sizes or quantities or weight of the tender documents, a tenderer may use an envelope, package or container. The Tenderer shall deliver the Tender in a single sealed envelope, or in a single sealed package, or in a single sealed container bearing the name and Reference number of the Tender, addressed to the Procuring Entity and a warning not to open before the time and date for Tender opening date. Within the single envelope, package or container, the Tenderer shall place the following separate, sealed envelopes:

- in an envelope or package or container marked “ORIGINAL”, all documents comprising the Tender, as described in ITT 11; and
- in an envelope or package or container marked “COPIES”, all required copies of the Tender; and
- if alternative Tenders are permitted in accordance with ITT 15, and if relevant:
  - in an envelope or package or container marked “ORIGINAL –ALTERNATIVE TENDER”, the alternative Tender; and
  - in the envelope or package or container marked “COPIES- ALTERNATIVE TENDER”, all required copies of the alternative Tender.

The inner envelopes or packages or containers shall:  
Bear the name and address of the Procuring Entity.  
Bear the name and address of the Tenderer; and  
Bear the name and Reference number of the Tender.

If an envelope or package or container is not sealed and marked as required, the *Procuring Entity* will assume no responsibility for the misplacement or premature opening of the Tender. Tenders that are misplaced or opened prematurely will not be accepted.

**Deadline for Submission of Tenders**

Tenders must be received by the Procuring Entity at the address specified in the TDS and no later than the date and time also specified in the TDS. When so specified in the TDS, Tenderers shall have the option of submitting their Tenders electronically. Tenderers submitting Tenders electronically shall follow the electronic Tender submission procedures specified in the TDS.

The Procuring Entity may, at its discretion, extend the deadline for the submission of Tenders by amending the Tender Documents in accordance with ITT 8, in which case all rights and obligations of the Procuring Entity and Tenderers previously subject to the deadline shall thereafter be subject to the deadline as extended.

The Procuring Entity shall prepare minutes of the Tender Opening that shall include, as a minimum:

the name of the Tenderer and whether there is a withdrawal, substitution, or modification;  
the Tender Price, per lot (contract) if applicable, including any discounts;  
any alternative Tenders;  
the presence or absence of a Tender Security, if one was required.  
number of pages of each tender document submitted.

The Tenderers' representatives who are present shall be requested to sign the minutes. The omission of a Tenderer's signature on the minutes shall not invalidate the contents and effect of the minutes. A copy of the tender opening register shall be distributed to all Tenderers upon request.

### **Late Tenders**

25.1 The Procuring Entity shall not consider any Tender that arrives after the deadline for submission of tenders, in accordance with IIT 24. Any Tender received by the Procuring Entity after the deadline for submission of Tenders shall be declared late, rejected, and returned unopened to the Tenderer.

### **Withdrawal, Substitution, and Modification of Tenders**

A Tenderer may withdraw, substitute, or modify its Tender after it has been submitted by sending a written notice, duly signed by an authorized representative, and shall include a copy of the authorization in accordance with IIT 22.3, (except that withdrawal notices do not require copies). The corresponding substitution or modification of the Tender must accompany the respective written notice. All notices must be:

Prepared and submitted in accordance with IIT 22 and IIT 23 (except that withdrawals notices do not require copies), and in addition, the respective envelopes shall be clearly marked

“WITHDRAWAL,” “SUBSTITUTION,” “MODIFICATION;” and

Received by the Procuring Entity prior to the deadline prescribed for submission of Tenders, in accordance with IIT 24.

Tenders requested to be withdrawn in accordance with IIT 26.1 shall be returned unopened to the Tenderers. No Tender may be withdrawn, substituted, or modified in the interval between the deadline for submission of Tenders and the expiration of the period of Tender validity specified by the Tenderer on the Form of Tender or any extension thereof.

### **Tender Opening**

Except in the cases specified in IIT 23 and IIT 26.2, the Procuring Entity shall publicly open and read out all Tenders received by the deadline, at the date, time and place specified in the TDS, in the presence of Tenderers' designated representatives who chooses to attend. Any specific electronic Tender opening procedures required if electronic Tendering is permitted in accordance with IIT 24.1, shall be as specified in the TDS.

First, envelopes marked “WITHDRAWAL” shall be opened and read out and the envelopes with the corresponding Tender shall not be opened, but returned to the Tenderer. No Tender withdrawal shall be permitted unless the corresponding withdrawal notice contains a valid authorization to request the withdrawal and is read out at Tender opening.

Next, envelopes marked “SUBSTITUTION” shall be opened and read out and exchanged with the corresponding Tender being substituted, and the substituted Tender shall not be opened, but returned to the Tenderer. No Tender substitution shall be permitted unless the corresponding substitution notice contains a valid authorization to request the substitution and is read out at Tender opening.

Next, envelopes marked “MODIFICATION” shall be opened and read out with the corresponding Tender. No Tender modification shall be permitted unless the corresponding modification notice contains a valid authorization to request the modification and is read out at Tender opening.

Next, all remaining envelopes shall be opened one at a time, reading out: the name of the Tenderer and whether there is a modification; the total Tender Price, per lot (contract) if applicable, including any discounts and alternative Tenders; the presence or absence of a Tender Security or Tender- Securing Declaration, if required; and any other details as the Procuring Entity may consider appropriate.

Only Tenders, alternative Tenders and discounts that are opened and read out at Tender opening shall be considered further for evaluation. The Form of Tender and pages of the Bills of Quantities are to be initialed by the members of the tender opening committee attending the opening. The number of representatives of the Procuring Entity to sign shall be specified in the TDS.

At the Tender Opening, the Procuring Entity shall neither discuss the merits of any Tender nor reject any Tender (except for late Tenders, in accordance with ITT 25.1).

## **E. Evaluation and Comparison of**

### **Tenders Confidentiality**

Information relating to the evaluation of Tenders and recommendation of contract award shall not be disclosed to Tenderers or any other persons not officially concerned with the Tender process until information on Intention to Award the Contract is transmitted to all Tenderers in accordance with ITT 46.

Any effort by a Tenderer to influence the Procuring Entity in the evaluation of the Tenders or Contract award decisions may result in the rejection of its tender.

Notwithstanding ITT 28.2, from the time of tender opening to the time of contract award, if a tenderer wishes to contact the Procuring Entity on any **matter related to the tendering process, it shall do so in writing.**

### **Clarification of Tenders**

To assist in the examination, evaluation, and comparison of the tenders, and qualification of the tenderers, the Procuring Entity may, at its discretion, ask any tenderer for a clarification of its tender, given a reasonable time for a response. Any clarification submitted by a tenderer that is not in response to a request by the Procuring Entity shall not be considered. The Procuring Entity's request for clarification and the response shall be in writing. No change, including any voluntary increase or decrease, in the prices or substance of the tender shall be sought, offered, or permitted, except to confirm the correction of arithmetic errors discovered by the Procuring Entity in the evaluation of the tenders, in accordance with ITT 33.

If a tenderer does not provide clarifications of its tender by the date and time set in the Procuring Entity's request for clarification, its Tender may be rejected.

### **Deviations, Reservations, and Omissions**

During the evaluation of tenders, the following definitions apply:

“Deviation” is a departure from the requirements specified in the tender document;

“Reservation” is the setting of limiting conditions or withholding from complete acceptance of the requirements specified in the tender document; and

“Omission” is the failure to submit part or all of the information or documentation required in the Tender document.

### **Determination of Responsiveness**

The Procuring Entity's determination of a Tender's responsiveness is to be based on the contents of the tender itself, as defined in ITT 13.

A substantially responsive Tender is one that meets the requirements of the Tender document without material deviation, **reservation, or omission. A material deviation, reservation, or omission is one that, if accepted, would:**

affect in any substantial way the scope, quality, or performance of the Works specified in the Contract; or limit in any substantial way, inconsistent with the tender document, the Procuring Entity's rights or the tenderer's obligations under the proposed contract; or if rectified, would unfairly affect the competitive position of other tenderers presenting substantially responsive tenders.

The Procuring Entity shall examine the technical aspects of the tender submitted in accordance with ITT 18, to confirm that all requirements of Section VII, Works' Requirements have been met without any material deviation, reservation or omission.

If a tender is not substantially responsive to the requirements of the tender document, it shall be rejected by the Procuring Entity and may not subsequently be made responsive by correction of the material deviation, reservation, or omission.

### **Non-material Non-conformities**

Provided that a tender is substantially responsive, the Procuring Entity may waive any non-conformities in the tender.

Provided that a Tender is substantially responsive, the Procuring Entity may request that the tenderer submit the necessary information or documentation, within a reasonable period, to rectify nonmaterial non-conformities in the tender related to documentation requirements. Requesting information or documentation on such non- conformities shall not be related to any aspect of the price of the tender. Failure of the tenderer to comply with the request may result in the rejection of its tender.

Provided that a tender is substantially responsive, the Procuring Entity shall rectify quantifiable nonmaterial non-conformities related to the Tender Price. To this effect, the Tender Price shall be adjusted, for comparison purposes only, to reflect the price of a missing or non-conforming item or component in the manner specified in the **TDS**.

### **Arithmetical Errors**

The tender sum as submitted and read out during the tender opening shall be absolute and final and shall not be the subject of correction, adjustment or amendment in any way by any person or entity.

Provided that the Tender is substantially responsive, the Procuring Entity shall handle errors on the following basis:

Any error detected if considered a major deviation that affects the substance of the tender, shall lead to disqualification of the tender as non-responsive.

Any errors in the submitted tender arising from a miscalculation of unit price, quantity, and subtotal and total bid price shall be considered as a major deviation that affects the substance of the tender and shall lead to disqualification of the tender as non-responsive. And

if there is a discrepancy between words and figures, the amount in words shall prevail

Tenderers shall be notified of any error detected in their bid during the notification of a ward.

## Currency provisions

Tenders will be priced in Kenya Shillings only. Tenderers quoting in currencies other than in Kenya shillings will be determined non-responsive and rejected.

## Margin of Preference and Reservations

No margin of preference shall be allowed on contracts for small works.

Where it is intended to reserve the contract to specific groups under Small and Medium Enterprises, or enterprise of women, youth and/or persons living with disability, who are appropriately registered as such by the authority to be specified in the TDS, a procuring entity shall ensure that the invitation to tender specifically indicates that only businesses/firms belonging to those specified groups are the only ones eligible to tender. Otherwise, if no so stated, the invitation will be open to all tenderers.

## Nominated Subcontractors

Unless otherwise stated in the **TDS**, the Procuring Entity does not intend to execute any specific elements of the Works by subcontractors selected in advance by the Procuring Entity.

Tenderers may propose subcontracting up to the percentage of total value of contracts or the volume of works as specified in the TDS. Subcontractors proposed by the Tenderer shall be fully qualified for their parts of the Works.

The subcontractor's qualifications shall not be used by the Tenderer to qualify for the Works unless their specialized parts of the Works were previously designated by the Procuring Entity in the TDS as can be met by subcontractors referred to hereafter as 'Specialized Subcontractors', in which case, the qualifications of the Specialized Subcontractors proposed by the Tenderer may be added to the qualifications of the Tenderer

## Evaluation of Tenders

The Procuring Entity shall use the criteria and methodologies listed in this ITT and Section III, Evaluation and Qualification Criteria. No other evaluation criteria or methodologies shall be permitted. By applying the criteria and methodologies the Procuring Entity shall determine the Best Evaluated Tender in accordance with ITT 40.

To evaluate a Tender, the Procuring Entity shall consider the following:

- price adjustment due to discounts offered in accordance with ITT 16;
- converting the amount resulting from applying (a) and (b) above, if relevant, to a single currency in accordance with ITT 39;
- price adjustment due to quantifiable nonmaterial non-conformities in accordance with ITT 30.3; and
- any additional evaluation factors specified in the **TDS** and Section III, Evaluation and Qualification Criteria.

The estimated effect of the price adjustment provisions of the Conditions of Contract, applied over the period of execution of the Contract, shall not be considered in Tender evaluation.

In the case of multiple contracts or lots, Tenderers shall be allowed to tender for one or more lots and the methodology to determine the lowest evaluated cost of the lot (contract) combinations, including any discounts offered in the Form of Tender, is specified in Section III, Evaluation and Qualification Criteria.

## **Comparison of Tenders**

The Procuring Entity shall compare the evaluated costs of all substantially responsive Tenders established in accordance with ITT 38.2 to determine the Tender that has the lowest evaluated cost.

### **Abnormally Low Tenders**

An Abnormally Low Tender is one where the Tender price, in combination with other elements of the Tender, appears so low that it raises material concerns as to the capability of the Tenderer in regards to the Tenderer's ability to perform the Contract for the offered Tender Price or that genuine competition between Tenderers is compromised.

In the event of identification of a potentially Abnormally Low Tender, the Procuring Entity shall seek written clarifications from the Tenderer, including detailed price analyses of its Tender price in relation to the subject matter of the contract, scope, proposed methodology, schedule, allocation of risks and responsibilities and any other requirements of the Tender document.

After evaluation of the price analyses, in the event that the Procuring Entity determines that the Tenderer has failed to demonstrate its capability to perform the Contract for the offered Tender Price, the Procuring Entity shall reject the Tender.

### **Abnormally High Tenders**

An abnormally high price is one where the tender price, in combination with other constituent elements of the Tender, appears unreasonably too high to the extent that the Procuring Entity is concerned that it (the Procuring Entity) may not be getting value for money or it may be paying too high a price for the contract compared with market prices or that genuine competition between Tenderers is compromised.

In case of an abnormally high tender price, the Procuring Entity shall make a survey of the market prices, check if the estimated cost of the contract is correct and review the Tender Documents to check if the specifications, scope of work and conditions of contract are contributory to the abnormally high tenders. The Procuring Entity may also seek written clarification from the tenderer on the reason for the high tender price. The Procuring Entity shall proceed as follows:

If the tender price is abnormally high based on wrong estimated cost of the contract, the Procuring Entity may accept or not accept the tender depending on the Procuring Entity's budget considerations.

If specifications, scope of work and/or conditions of contract are contributory to the abnormally high tender prices, the Procuring Entity shall reject all tenders and may retender for the contract based on revised estimates, specifications, scope of work and conditions of contract, as the case may be.

If the Procuring Entity determines that the Tender Price is abnormally too high because genuine competition between tenderers is compromised (often due to collusion, corruption or other manipulations), the Procuring Entity shall reject all Tenders and shall institute or cause competent Government Agencies to institute an investigation on the cause of the compromise, before retendering.

### **Unbalanced and/or Front-Loaded Tenders**

If in the Procuring Entity's opinion, the Tender that is evaluated as the lowest evaluated price is seriously unbalanced and/or front loaded, the Procuring Entity may require the Tenderer to provide written clarifications. Clarifications may include detailed price analyses to demonstrate the consistency of the tender prices with the scope of works, proposed methodology, schedule and any other requirements of the Tender document.

After the evaluation of the information and detailed price analyses presented by the Tenderer, the Procuring Entity may as appropriate:

accept the Tender; or

require that the total amount of the Performance Security be increased at the expense of the Tenderer to a level not exceeding a 30% of the Contract Price; or agree on a payment mode that eliminates the inherent risk of the Procuring Entity paying too much for undelivered works; or reject the Tender,

## **Qualifications of the Tenderer**

The Procuring Entity shall determine to its satisfaction whether the eligible Tenderer that is selected as having submitted the lowest evaluated cost and substantially responsive Tender, meets the qualifying criteria specified in Section III, Evaluation and Qualification Criteria.

The determination shall be based upon an examination of the documentary evidence of the Tenderer's qualifications submitted by the Tenderer, pursuant to IIT 19. The determination shall not take into consideration the qualifications of other firms such as the Tenderer's subsidiaries, parent entities, affiliates, subcontractors (other than Specialized Subcontractors if permitted in the Tender document), or any other firm(s) different from the Tenderer.

An affirmative determination shall be a prerequisite for award of the Contract to the Tenderer. A negative determination shall result in disqualification of the Tender, in which event the Procuring Entity shall proceed to the Tenderer who offers a substantially responsive Tender with the next lowest evaluated price to make a similar determination of that Tenderer's qualifications to perform satisfactorily.

An Abnormally Low Tender is one where the Tender price, in combination with other elements of the Tender, appears so low that it raises material concerns as to the capability of the Tenderer in regards to the Tenderer's ability to perform the Contract for the offered Tender Price.

In the event of identification of a potentially Abnormally Low Tender, the Procuring Entity shall seek written clarifications from the Tenderer, including detailed price analyses of its Tender price in relation to the subject matter of the contract, scope, proposed methodology, schedule, allocation of risks and responsibilities and any other requirements of the Tender document.

After evaluation of the price analyses, if the Procuring Entity determines that the Tenderer has failed to demonstrate its capability to perform the Contract for the offered Tender Price, the Procuring Entity shall reject the Tender.

## **Best Evaluated Tender**

Having compared the evaluated prices of Tenders, the Procuring Entity shall determine the Best Evaluated Tender. The Best Evaluated Tender is the Tender of the Tenderer that meets the Qualification Criteria and whose Tender has been determined to be: Most responsive to the Tender document; and the lowest evaluated price.

## **Procuring Entity's Right to Accept Any Tender, and to Reject Any or All Tenders.**

44.1 The Procuring Entity reserves the right to accept or reject any Tender and to annul the Tender process and reject all Tenders at any time prior to Contract Award, without thereby incurring any liability to Tenderers. In case of annulment, all Tenderers shall be notified with reasons and all Tenders submitted and specifically, Tender securities, shall be promptly returned to the Tenderers

## **F. Award of Contract**

### **Award Criteria**

45.1 The Procuring Entity shall award the Contract to the successful tenderer whose tender has been determined to be the Lowest Evaluated Tender.

### **Notice of Intention to enter into a Contract**

46.1 Upon award of the contract and prior to the expiry of the Tender Validity Period the Procuring Entity shall issue a Notification of Intention to Enter into a Contract / Notification of award to all tenderers which shall contain, at a minimum, the following information:

the name and address of the Tenderer submitting the successful tender; the Contract price of the successful tender;

a statement of the reason(s) the tender of the unsuccessful tenderer to whom the letter is addressed was unsuccessful, unless the price information in (c) above already reveals the reason;

the expiry date of the Standstill Period; and instructions on how to request a debriefing and/or submit a complaint during the standstill period;

### **Standstill Period**

The Contract shall not be signed earlier than the expiry of a Standstill Period of 14 days to allow any dissatisfied tender to launch a complaint. Where only one Tender is submitted, the Standstill Period shall not apply.

Where a Standstill Period applies, it shall commence when the Procuring Entity has transmitted to each Tenderer the Notification of Intention to Enter **into a Contract with the successful Tenderer.**

### **Debriefing by the Procuring Entity**

On receipt of the Procuring Entity's Notification of Intention to Enter into a Contract referred to in IIT 46, an unsuccessful tenderer may make a written request to the Procuring Entity for a debriefing on specific issues or concerns regarding their tender. The Procuring Entity shall provide the debriefing within five days of receipt of the request.

Debriefings of unsuccessful Tenderers may be done in writing or verbally. The Tenderer shall bear its own costs of attending **such a debriefing meeting.**

### **Letter of Award**

Prior to the expiry of the Tender Validity Period and upon expiry of the Standstill Period specified in IIT 42.1, upon addressing a complaint that has been filed within the Standstill Period, the Procuring Entity shall transmit the Letter of Award to the successful Tenderer. The letter of award shall request the successful tenderer to furnish the Performance Security within 21 days of the date of the letter.

### **Signing of Contract**

Upon the expiry of the fourteen days of the Notification of Intention to enter into contract and upon the parties meeting their respective statutory requirements, the Procuring Entity shall send the successful Tenderer the Contract Agreement.

Within fourteen (14) days of receipt of the Contract Agreement, the successful Tenderer shall sign, date, and return it to the Procuring Entity.

The written contract shall be entered into within the period specified in the notification of award and before expiry of the tender validity period

## **Appointment of Adjudicator**

The Procuring Entity proposes the person named in the TDS to be appointed as Adjudicator under the Contract, at the hourly fee specified in the TDS, plus reimbursable expenses. If the Tenderer disagrees with this proposal, the Tenderer should so state in his Tender. If, in the Letter of Acceptance, the Procuring Entity does not agree on the appointment of the Adjudicator, the Procuring Entity will request the Appointing Authority designated in the Special Conditions of Contract (SCC) pursuant to Clause 23.1 of the General Conditions of Contract (GCC), to appoint the Adjudicator.

## **Performance Security**

Within twenty-one (21) days of the receipt of the Letter of Acceptance from the Procuring Entity, the successful Tenderer shall furnish the Performance Security and, any other documents required in the TDS, in accordance with the General Conditions of Contract, subject to ITT 40.2 (b), using the Performance Security and other Forms included in Section X, Contract Forms, or another form acceptable to the Procuring Entity. A foreign institution providing a bank guarantee shall have a correspondent financial institution located in Kenya, unless the Procuring Entity has agreed in writing that a correspondent bank is not required.

Failure of the successful Tenderer to submit the above-mentioned Performance Security and other documents required in the TDS, or sign the Contract shall constitute sufficient grounds for the annulment of the award and forfeiture of the Tender Security. In that event the Procuring Entity may award the Contract to the Tenderer offering the next Best Evaluated Tender.

Performance security shall not be required for contracts estimated to cost less than Kenya shillings five million shillings.

## **Publication of Procurement Contract**

Within fourteen days after signing the contract, the Procuring Entity shall publish the awarded contract at its notice boards and websites; and on the Website of the Authority. At the minimum, the notice shall contain the following information:

name and address of the Procuring Entity;  
name and reference number of the contract being awarded, a summary of its scope and the selection method used;  
the name of the successful Tenderer, the final total contract price, the contract duration.  
dates of signature, commencement and completion of contract;  
names of all Tenderers that submitted Tenders, and their Tender prices as read out at Tender opening.

## **Procurement Related Complaints**

54.1 The procedures for making Procurement-related Complaints are as specified in the TDS.

## Section II - Tender Data Sheet (TDS)

The following specific data shall complement, supplement, or amend the provisions in the Instructions to Tenderers (ITT). Whenever there is a conflict, the provisions herein shall prevail over those in ITT.

Reference to ITC Clause	PARTICULARS OF APPENDIX TO INSTRUCTIONS TO TENDERS
<b>A. General</b>	
ITT 1.1	Name of the Contract is: <b>Proposed Construction to Completion of 45 capacity Science Laboratory at St. Peter's Nanga Secondary School</b> The Reference Number of the Contract is: <b>KSMCTRL/NGCDF/CSDU/EDU/NNGA/1/2023/24</b>
ITT 2.4	The Information made available on competing firms is as follows
ITT 2.4	The firms that provided consulting services for the contract being tendered for are: <del>COUNTY WORKS OFFICER – Kisumu</del>
ITT 3.1	Maximum number of members in the Joint Venture (JV) shall be: <i>N/A</i>
<b>B. Contents of Tender Document</b>	
ITT 7.1	The Tenderer will submit any request for clarifications in writing at the Address <b>FUND ACCOUNT MANAGER</b> Kisumu National Government Constituency Development Fund At DCC Kisumu Central Headquarters P.O Box 1077-40100 Kisumu <a href="mailto:cdfkisumucentral@ngcdf.go.ke">cdfkisumucentral@ngcdf.go.ke</a>  to reach the Procuring Entity not later than <b>JULY 25<sup>th</sup>, 2024</b>  The procuring Entity shall publish its responses on the website <a href="http://www.ngcdf.go.ke">www.ngcdf.go.ke</a>
ITT 7.2	(PRE-TENDER SITE VISIT NOT MANDATORY)
ITT 7.3	The Tenderer will submit any questions in writing, to reach the Procuring Entity not later than 5 DAYS before the meeting.
ITT 7.5	The Procuring Entity's website where Minutes of the pre-Tender meeting and the pre-arranged pretender will be published is <a href="http://www.ngcdf.go.ke">www.ngcdf.go.ke</a>
ITT 9.1	For Clarification of Tender purposes, for obtaining further information and for purchasing tender documents, the Procuring Entity's address is: <b>FUND ACCOUNT MANAGER</b> <b>Kisumu Central National Government Constituency Development Fund</b> <b>At DCC Kisumu Central Headquarters</b> <b>P.O Box 1077-40100 Kisumu,</b> <b>cdfkisumucentral@ngcdf.go.ke</b>
<b>C. Preparation of Tenders</b>	
ITT 11.1 (h)	The Tenderer shall submit the following additional documents in its Tender: <i>[list any additional document not already listed in ITT 11.1 that must be submitted with the Tender. The list of additional documents should include the following:]</i>
ITT 13.1	Alternative Tenders SHALL NOT be considered.
ITT 13.2	Alternative times for completion SHALL NOT be permitted.
ITT 13.4	The prices quoted by the Tenderer shall be: FIXED
ITT 14.5	Foreign currency requirements NOT ALLOWED
ITT 15.2 (a)	Foreign currency requirements <b>allowed/not allowed.</b>
ITT 18.1	The Tender validity period shall be ____ <i>[insert a number of days that is a multiple of seven counting as of the deadline for Tender submission]</i> days.

ITT 18.3	The Number of days beyond the expiry of the initial tender validity period will be _____days.  The Tender price shall be adjusted by the following percentages of the tender price:
Reference to ITC Clause	<b>PARTICULARS OF APPENDIX TO INSTRUCTIONS TO TENDERS</b>
	By _% of the local currency portion of the Contract price adjusted to reflect local inflation during the period of extension, and  By_ % the foreign currency portion of the Contract price adjusted to reflect the international inflation during the period of extension.
ITT 19.1	Tender shall provide a <b>Tender Security</b> The type of Tender security shall be <b>80,000 of the Tender sum (From a reputable bank or approved Insurance Company)</b>
ITT 20.1	In addition to the original of the Tender, the number of copies is: <b>1 Copies</b>
ITT 20.3	The written confirmation of authorization to sign on behalf of the Tenderer shall consist of: <b>POWER OF ATTORNEY (Tender Specific)</b>
<b>D. Submission and Opening of Tenders</b>	
ITT 22.1	(A) (For Tender submission purposes only, the Procuring Entity's address is:  <b>FUND ACCOUNT MANAGER</b> Kisumu Central National Government Constituency Development Fund At DCC Kisumu Central Headquarters P.O Box 1077-40100 <a href="mailto:cdfkisumucentral@ngcdf.go.ke">cdfkisumucentral@ngcdf.go.ke</a>  (5) Tenders <b>shall not submit</b> tenders electronically.
ITT 25.1	The Tender opening shall take place at the time and the address for Opening of Tenders Provided below: <b>FUND ACCOUNT MANAGER</b> Kisumu Central National Government Constituency Development Fund At DCC Kisumu Central Headquarters P.O Box 1077-40100 Kisumu <a href="mailto:cdfkisumucentral@ngcdf.go.ke">cdfkisumucentral@ngcdf.go.ke</a>  Tender Closing time; <b>JULY 25<sup>th</sup>, 2024</b> at 11.00 AM in the NGCDF Offices Grounds
ITT 25.1	If Tenderers are NOT allowed to submit Tenders electronically
<b>E. Evaluation, and Comparison of Tenders</b>	
ITT 30.3	The adjustment shall be based on the <b>Average</b> price of the item or component as quoted in other substantially responsive Tenders. If the price of the item or component cannot be derived from the price of other substantially responsive Tenders, the Procuring Entity shall use its best estimate.
ITT 32.1	The currency that shall be used for Tender evaluation and comparison purposes only to convert at the selling exchange rate all Tender prices expressed in various currencies into a single currency is: <b>Kenya Shillings</b>  The source of exchange rate shall be: <b>The Central bank of Kenya</b> (mean rate)  The date for the exchange rate shall be: <b>the deadline date for Submission of the Tenders.</b>
ITT 33.2	A margin of preference <b>Shall not Apply.</b>
ITT 33.4	The invitation to tender is extended to the following group that qualify for Reservations <b>open to all eligible bidders</b>
ITT 34.1	At this time, the Procuring Entity <b>does not intend</b> to execute certain specific parts of the Works by subcontractors selected in advance.

ITT 34.2	Contractor's may propose subcontracting: Maximum percentage of subcontracting permitted is: <i>10 % of the total contract amount</i> . Tenderers planning to subcontract more than 10% of total volume of work shall specify, in the Form of Tender, the activity (ies) or parts of the Works to be subcontracted along with complete details of the subcontractors and their qualification and experience.
Reference to ITC Clause	<b>PARTICULARS OF APPENDIX TO INSTRUCTIONS TO TENDERS</b>
ITT 34.3	<p>The parts of the Works for which the Procuring Entity permits Tenderers to propose Specialized Subcontractors are designated as follows: N/A</p> <p>For the above-designated parts of the Works that may require Specialized Subcontractors, the relevant qualifications of the proposed Specialized Subcontractors will be added to the qualifications of the Tenderer for the purpose of evaluation.</p>
ITT 35.2 (e)	Additional requirements apply. These are detailed in the evaluation criteria in Section III, Evaluation and Qualification Criteria.
ITT 48.1	Other documents required in addition to the Performance Security are <b>None</b>
ITT 50.1	<p>The procedures for making a Procurement-related Complaint are detailed in the "Notice of Intention to Award the Contract" herein and are also available from the PPRA Website <a href="http://www.ppra.go.ke">www.ppra.go.ke</a> or <a href="mailto:emailcomplaints@ppra.go.ke">emailcomplaints@ppra.go.ke</a>.</p> <p>If a Tenderer wishes to make a Procurement-related Complaint, the Tenderer should submit its complaint following these procedures, in writing (by the quickest means available, that is either by hand delivery or email to: For the attention: <b>FUND ACCOUNT MANAGER</b> Procuring Entity: <b>KISUMU CENTRAL NG-CDF</b> Email address: <a href="mailto:cdfkisumucentral@ngcdf.go.ke">cdfkisumucentral@ngcdf.go.ke</a></p> <p>In summary, a Procurement-related Complaint may challenge any of the following (among others): the terms of the Tender Documents; and the Procuring Entity's decision to award the contract.</p>

## **SECTION III - EVALUATION AND QUALIFICATION CRITERIA**

### **QUALIFICATION CRITERIA**

#### **General Provisions**

Wherever a Tenderer is required to state a monetary amount, Tenderers should indicate the Kenya Shilling equivalent using the rate of exchange determined as follows:

For construction turnover or financial data required for each year - Exchange rate prevailing on the last day of the respective calendar year (in which the amounts for that year is to be converted) was originally established.  
Value of single contract - Exchange rate prevailing on the date of the contract signature.

Exchange rates shall be taken from the publicly available source identified in the ITT 14.3. Any error in determining the exchange rates in the Tender may be corrected by the Procuring Entity.

This section contains the criteria that the Employer shall use to evaluate tender and qualify tenderers. No other factors, methods or criteria shall be used other than specified in this tender document. The Tenderer shall provide all the information requested in the forms included in Section IV, Tendering Forms.

### **EVALUATION AND CONTRACT AWARD CRITERIA**

After tender opening, the tenders will be evaluated in 4 stages, namely:

- i) Determination of Responsiveness. ii) Detailed Technical Examination.
- Financial Evaluation.
- Combination of Technical, Tender Sums Comparison and Financial Score.
- Post qualification: Due diligence.

### **STAGE 1- DETERMINATION OF RESPONSIVENESS**

#### **PRELIMINARY EXAMINATION**

This stage of evaluation shall involve examination of the pre-qualification conditions as set out in the Tender Advertisement Notice or Letter of Invitation to Tender and any other conditions stated in the bid document.

These conditions shall include, among other things, the following:

1. **Attach certified copy of Company certificate of incorporation /registration.**
2. **Attach certified copy of CR12 with copies of directors' IDs (should be within (12) months).**
3. **Attach certified Copy of Valid Tax compliance certificate**
4. **Attach certified Copy of KRA PIN certificate**
5. **Attach Certified valid Single Business Permit/License issued by the County Government**
6. **Attach Certified Copies of Audited Financial Report from a Reputable Firm for the last three years (2021, 2022 and 2023)**
7. **Attach a Certified Copy of the National Construction Authority Certificate and License(Building Works) NCA 6 and above**
8. **Provision of Bid Security Ksh 80,000 from reputable bank or approved Insurance Company**
9. **Completely filled in and Stamped, Confidential Business Questionnaire, Form of Tender, Disclosure of Interest Form, Certificate of Independent Tender Determination, Form SD1 and SD2**
10. **Proof of Similar Work of Similar Magnitude;**
11. **All pages MUST be sequentially serialized/ paged**
12. **Prices quoted should be inclusive of all taxes and remain valid for a period of 120 days from the day of opening the bids.**

The employer may seek further clarification/confirmation if necessary to confirm authenticity/compliance of any condition of the tender.

***The tenderers who do not satisfy any of the above requirements shall be considered Non- Responsive and their tenders will not be evaluated further.***

## STAGE 2 - COMPLETENESS OF TENDER DOCUMENT

The tender document shall be examined based on clause 2.2 of the Instruction to Tenderers which states as follows:

The tenderers will be required to provide evidence for eligibility of the award of the tender by satisfying the employer of their eligibility under sub clause 2.1 of Instruction to Tenderers and adequacy of resources to effectively carry out the subject contract. The tenderers shall be required to fill the Standards Forms provided for the purposes of providing the required information. The tenderers may also attach the required information if they so desire.

The award of points for the **STANDARD FORMS** considered in this section shall be as shown below

### PARAMETER

### MAXIMUM POINTS

	<u>PARAMETER</u>	<u>MAXIMUM POINTS</u>
(i)	Form Of Tender	1.5
(ii)	Tender Questionnaire	2.5
(iii)	Confidential Business Questionnaire and Certificate of Independent Tender Determination and The Self Declaration of the Tenderer	2.5
(iv)	Key personnel	7.5
(v)	Contracts Completed in the last Five (5) years	15
(vi)	Schedules of on-going projects	5
(vii)	Schedules of contractor's equipment	5
(viii)	Audited Financial Report for the last 3 years	5
(ix)	Evidence of Financial Resources	2.5
(x)	Name, Address and Telephone of Banks (Contractor to provide)	2.5
(xi)	Litigation History	1
(xii)	Sanctity of the tender document as in accordance with clause 5 of instruction to tenderer	5
	<b>TOTAL</b>	<b>50</b>

Any bidder who scores **35 points** and above shall be considered for further evaluation.

The Technical Evaluation Score will be carried forward to **STAGE 4**

The detailed scoring plan shall be as shown in table 1 below: - **TABLE 1**

**TABLE 1:**

Item	Description	Point Scored	Max. Point
i	<b>Form of Tender</b> Signed and stamped 1.5 Signed but not stamped or vice versa 1 Not signed nor stamped 0		1.5
ii	<b>Tender Questionnaire Form</b> Completely filled 2.5 Partially filled 1.5 Not filled 0		2.5
iii	<b>Confidential Business Questionnaire Form.</b> Completely filled 2.5 Partially filled 1.5 Not filled 0		2.5
iv	<b>Key Personnel (Attach evidence)</b>		7.5
	<b>Director of the firm</b> Holder of degree or diploma in relevant Engineering field 2 Holder of certificate in relevant Engineering field 1.5 Holder of trade test certificate in relevant Engineering field 1 No relevant certificate 0		2
	<b>At least 1No. degree/diploma of key personnel in relevant Engineering field</b> With over 10 years relevant experience 2 With over 5 years relevant experience 1.5 With under 5 years relevant experience 0.5		2
	<b>At least 1No certificate holder of key personnel in relevant Engineering field</b> With over 10 years relevant experience 1.5 With over 5 years relevant experience 1 With under 5 years relevant experience 0.5		1.5

	<b>At least 2No artisan (trade test certificate in relevant Engineering field)</b> Artisan with over 10 years relevant experience 2 Artisan with under 10 years relevant experience 1.5 Non skilled worker with over 10 years relevant experience 0.5		2	
v	<b>Contract completed in the last five (5) years (Max of 5 No. Projects) [Attach Documentary Evidence]</b> Project of similar nature, complexity and magnitude 7.5 Project of similar nature but of lower value than the one in consideration 4 No completed project of similar nature 0		7.5	
vi	<b>On-going projects (Max of 5 No. Projects) [Attach Documentary Evidence]</b> Project of similar nature, complexity and magnitude 5 Project of similar nature but of lower value than the one in consideration – 3.5 No ongoing project of similar nature 0		5	
vii	<b>Schedule of contractors equipment and transport (proof or evidence of ownership)</b> Means of transport (Vehicle) 2 No means of transport 0		2	5

	For each specific equipment required in the installation of the Work being tendered for. (Maximum No. of equipment to be considered – 3 No.)		3	
viii	<b>Financial Report</b> <b>Audited financial report (last three (3) years)</b> Turn over greater or equal to 5 times the cost of the project 5 Turn over greater or equal to 3 times the cost of the project 3 Turn over greater or equal to the cost of the project 2 Turn over below the cost of the project 1			5
ix	<b>Evidence of Financial Resources (cash in hand, lines of credit, over draft facility etc)</b> Has financial resources equal or above the cost of the project-- 5 Has financial resources below the cost of the project 2.5 Has not indicated sources of financial resources 0			5
x	<b>Name, Address and Telephone of Banks (Contractor to provide)</b> Provided 2.5 Not provided 0			2.5
xi	<b>Litigation History</b> Provided 1 Not Provided 0			1
xii	<b>Sanctity of the Tender Document</b> Having the document intact (not tempered with in any way) 5 Having mutilated or modified the tender document 0			5
	<b>TOTAL</b>			<b>50</b>

## **STAGE 3 - FINANCIAL EVALUATION**

The evaluation shall be in two sections  
Preliminary examinations and Tender sum  
Comparisons

### **PRELIMINARY EXAMINATIONS**

The preliminary examination in the Financial Evaluation shall be in accordance with clause 26 of Instruction to Tenderers.

#### **Comparison of rates**

The evaluation committee will compare rates from different bidders and note consistency of rates and front loading. The evaluation committee will judge and make an appropriate decision giving evidence.

### **TENDER SUMS COMPARISONS**

In this section, tender sums will be compared to the average of all sums for bidders who have qualified from **STAGE 3A** and score awarded to a maximum of 20 as shown below.

#### **1 Preliminary Average**

The tender sums of various binders, who qualify at **STAGE 3A** and the engineer's estimates, shall be reduced by omitting PC sums, provisional sums and contingency from the respectful amounts. The **average** of the adjusted tender sums so obtained shall be calculated.

Any tenderer whose tender percentage deviation is 20% higher or lower than the average obtained above, will be deemed to be unreasonably high or low and shall not be included in determining the mean in table 3, However their bids will still be evaluated further. The Engineer's estimate will also be subjected to the same treatment.

## 2. Working mean

The detailed scoring plan shall be as shown in table 3 below:

Item	Description	Score	Max. score
I	<p>Tender Sums: (The tender sums of binders, who qualify at STAGE 3A and the engineer's estimates, shall be reduced by omitting PC sums, Provisional sums and contingency from the respectful amounts. The average of the adjusted tender sums so obtained shall be calculated. The deviation of the reduced amounts in respect of each bidder from the average shall then be worked out as a percentage of the average (Rounded off to one (1) decimal point) and scores allocated as follows :-)</p> <p>o Deviation of between 0% and 1%..... 30</p> <p>o Deviation of between 1.1% and 2%..... 28.5</p> <p>o Deviation of between 2.1% and 3%..... 27</p> <p>o Deviation of between 3.1% and 4%..... 25.5</p> <p>o Deviation of between 4.1% and 5%..... 24</p> <p>o Deviation of between 5.1% and 6%..... 22.5</p> <p>o Deviation of between 6.1% and 7%..... 21</p> <p>o Deviation of between 7.1% and 8%..... 19.5</p> <p>o Deviation of between 8.1% and 9%..... 18</p> <p>o Deviation of between 9.1% and 10%..... 16.5</p> <p>o Deviation of between 10.1% and 11%..... 15</p> <p>o Deviation of between 11.1% and 12%..... 13.5</p> <p>o Deviation of between 12.1% and 13%..... 12</p> <p>o Deviation of between 13.1% and 14%..... 10.5</p> <p>o Deviation of between 14.1% and 15%..... 9</p> <p>o Deviation of between 15.1% and 16%..... 7.5</p> <p>o Deviation of between 16.1% and 17%..... 6</p> <p>o Deviation of between 17.1% and 18%..... 4.5</p> <p>o Deviation of between 18.1% and 19%..... 3</p> <p>o Deviation of between 19.1% and 20%..... 1.5</p> <p>o Deviation of 20.1% and above..... 0</p>		30
	TOTAL		30

**TABLE 3**

The Tender sum score will be carried forward to **FINAL STAGE**

**FINANCIAL SCORE**

The financial score (Fs) will be determined by comparing tender sums from all responsive bidders using the formulae below. The financial score will be allocated a maximum of 20%.

$$F_s = 20 \times F_m / F$$

Where  $F_s$  is the financial score,  $F_m$  is the lowest priced responsive financial bid and  $F$  is the price of the bid under consideration

**STAGE 4 - FINAL SCORE**

The total score will be combined sums of Technical, Tender Sums Comparison and Financial marks

As below

$$\begin{aligned} &\text{Technical (Ts) + Tender Sums Comparison (TSC) + Financial (Fs)} \\ &= T_s + TSC + F_s \end{aligned}$$

**RECOMMENDATION**

The lowest responsive bidder who scores 75% and above may be recommended for award.

**STAGE 4 - COMBINATION OF TECHNICAL, TENDER SUMS COMPARISON AND FINANCIAL SCORE.**

Evaluation shall combine the technical evaluation score, Tender Sum Comparison and financial score in order to obtain the Final score as shown below:

$$\begin{aligned} &\text{Technical Evaluation Score (TEs) + Tender sums Comparison Score (TSCs) + Financial Score} \\ &(\text{Fs}) + \text{ALL SCORES} = TEs + TSCs + F_s \\ &= 50\% + 20\% + 30\% \end{aligned}$$

**STAGE 5 - POST-QUALIFICATION**

An evaluation committee may, after tender evaluation, but prior to the award of the tender, conduct due diligence and present the report in writing to confirm and verify the qualifications of the tenderer who submitted the lowest evaluated responsive tender to be awarded the contract in accordance with this Act.

The conduct of due diligence may include obtaining confidential references from persons with whom the tenderer has had prior engagement.

To acknowledge that the report is a true reflection of the proceedings held, each member who was part of the due diligence by the evaluation committee shall initial each page of the report; and append his or her signature as well as their full name and designation.

## QUALIFICATION FORMS

### FORM EQU: EQUIPMENT

The Tenderer shall provide adequate information to demonstrate clearly that it has the capability to meet the requirements for the key equipment listed in Section III, Evaluation and Qualification Criteria. A separate Form shall be prepared for each item of equipment listed, or for alternative equipment proposed by the Tenderer.

Item of equipment	
Equipment information	Name of manufacturer
	Model and power rating
	Capacity
	Year of manufacture
Current status	Current location
	Details of current commitments
Source	Indicate source of the equipment  <input type="checkbox"/> Owned <input type="checkbox"/> Rented <input type="checkbox"/> Leased <input type="checkbox"/> Specially manufactured

Omit the following information for equipment owned by the Tenderer.

Owner	Name of owner	
	Address of owner	
	Telephone	Contact name and title
	Fax	Telex
Agreements	Details of rental / lease / manufacture agreements specific to the project	

Contractor's Representative and Key Personnel Schedule

Tenderers should provide the names and details of the suitably qualified Contractor's Representative and Key Personnel to perform the Contract. The data on their experience should be supplied using the Form PER-2 below for each candidate.  
Contractor' Representative and Key Personnel

**1.** Title of Position:

Name of Candidate:

Duration of Appointment

Time Commitment: for this position

Expected time Schedule for this  
Position

**2.** Title of Position:

Name of Candidate:

Duration of Appointment

Time Commitment: for this position

Expected time Schedule for this  
Position

**3.** Title of Position:

Name of Candidate:

Duration of Appointment

Time Commitment: for this position

Expected time Schedule for this  
Position

Title of Position:

Name of Candidate:

Duration of Appointment

Time Commitment: for this position

Expected time Schedule for this  
Position

**FORM PER-2:**

**Resume and Declaration - Contractor's Representative and Key Personnel**

Name of Tenderer:

Position #1:

Personnel Name Date of Birth  
Information

Address: Email:

Professional Qualifications:

Academic Qualifications:

Language Proficiency

Details

Telephone Contact (Manager/Personnel Officer)

Fax:

Job Title: Years with present Procuring Entity

Summarize professional experience in reverse chronological order. Indicate particular technical and managerial experience relevant to the project

Project	Role	Duration of Involvement	Relevant Experiences
---------	------	-------------------------	----------------------

**Declaration**

I, the undersigned.....certify that to the best of my knowledge and belief, the information contained in this Form PER-2 correctly describes myself, my qualifications and my experience.

I confirm that I am available as certified in the following table and throughout the expected time schedule for this position as provided in the Tender:

**Commitment**

**Details**

Commitment Details

Time of Commitment

I understand that any misrepresentation or omission in this Form may:

- be taken into consideration during Tender evaluation;
- result in my disqualification from participating in the Tender;
- result in my dismissal from the contract.

Name of Contractor's Representative or Key Personnel: .....

Signature: \_\_\_\_\_

Date: (day month year): \_\_\_\_\_

Counter signature of authorized representative of the Tenderer:

Signature: \_\_\_\_\_

Date: (day month year): \_\_\_\_\_

Historical Contract Non-Performance, Pending Litigation and Litigation History

Tenderer's Name: \_\_\_\_\_ Date: \_\_\_\_\_ JV Member's Name  
 \_\_\_\_\_ ITT No. and title: \_\_\_\_\_

<b>Non-Performed Contracts in accordance with Section III, Evaluation and Qualification Criteria</b>			
<input type="checkbox"/> Contract non-performance did not occur since 1 <sup>st</sup> January <i>[insert year]</i> specified in Section III, Evaluation and Qualification Criteria, Sub-Factor 2.1.			
<input type="checkbox"/> Contract(s) not performed since 1 <sup>st</sup> January <i>[insert year]</i> specified in Section III, Evaluation and Qualification Criteria, requirement 2.1			
Year	Non- performed portion of contract	Contract Identification	Total Contract Amount (current value, currency, exchange rate and Kenya Shilling equivalent)
<i>[insert year]</i>	<i>[insert amount and percentage]</i>	Contract Identification: <i>[indicate complete contract name/ number, and any other identification]</i>  Name of Procuring Entity: <i>[insert full name]</i>  Address of Procuring Entity: <i>[insert street/city/country]</i>  Reason(s) for nonperformance: <i>[indicate main reason(s)]</i>	<i>[insert amount]</i>
Pending Litigation, in accordance with Section III, Evaluation and Qualification Criteria			
<input type="checkbox"/> No pending litigation in accordance with Section III, Evaluation and Qualification Criteria, Sub-Factor 2.3.			
<input type="checkbox"/> Pending litigation in accordance with Section III, Evaluation and Qualification Criteria, Sub-Factor 2.3 as indicated below.			

Year of dispute	Amount in dispute (currency)	Contract Identification	Total Contract Amount (currency), Kenya Shilling Equivalent (exchange rate)
		Contract Identification: ___ Name of Procuring Entity: _____ Address of Procuring Entity: _____ Matter in dispute: _____ Party who initiated the dispute: __ Status of dispute: _____	
		Contract Identification: Name of Procuring Entity: Address of Procuring Entity: Matter in dispute: Party who initiated the dispute: Status of dispute:	

J Litigation History in accordance with Section III, Evaluation and Qualification Criteria

D No Litigation History in accordance with Section III, Evaluation and Qualification Criteria, Sub- Factor 2.4.  
 D Litigation History in accordance with Section III, Evaluation and Qualification Criteria, Sub- Factor 2.4 as indicated below.

Year of award	Outcome as percentage of Net Worth	Contract Identification	Total Contract Amount (currency), Kenya Shilling Equivalent (exchange rate)
<i>[insert year]</i>	<i>[insert percentage]</i>	Contract Identification: <i>[indicate complete contract name, number, and any other identification]</i> Name of Procuring Entity: <i>[insert full name]</i> Address of Procuring Entity: <i>[insert street/ city/ country]</i> Matter in dispute: <i>[indicate main issues in dispute]</i> Party who initiated the dispute: <i>[indicate "Procuring Entity" or "Contractor"]</i> Reason(s) for Litigation and award decision <i>[indicate main reason(s)]</i>	<i>[insert amount]</i>

Financial Situation and Performance

Tenderer's Name: \_\_\_\_\_ Date: \_\_\_\_\_ JV  
 Member's Name \_\_\_\_\_ IIT No. and title: \_\_\_\_\_

Financial Data

**Type of Financial information** \_\_\_\_\_ **Historic information for previous \_\_\_\_\_ years,**  
 \*Refer to IIT 15 for the exchange rate (currency)  
 (amount in currency, currency, exchange rate\*, USD equivalent)

	Year 1	Year 2	Year 3	Year 4	Year 5
Statement of Financial Position (Information from Balance Sheet)					
Total Assets (TA)					
Total Liabilities (TL)					
Total Equity/Net Worth (NW)					
Current Assets (CA)					
Current Liabilities (CL)					
Working Capital (WC)					
Information from Income Statement					
Total Revenue (TR)					
Profits Before Taxes (PBT)					
Cash Flow Information					
Cash Flow from Operating Activities					

## Sources of Finance

Specify sources of finance to meet the cash flow requirements on works currently in progress and for future contract commitments.

No.	Source of finance	Amount (Kenya Shilling equivalent)
1		
2		
3		

## Financial documents

The Tenderer and its parties shall provide copies of financial statements for 6 months pursuant Section III, Evaluation and Qualifications Criteria, Sub-factor 3.1. The financial statements shall:

reflect the financial situation of the Tenderer or in case of JV member, and not an affiliated entity (such as parent company or group member).

be independently audited or certified in accordance with local legislation.

be complete, including all notes to the financial statements.

correspond to accounting periods already completed and audited.

Attached are copies of financial statements<sup>1</sup> for the \_\_\_\_\_ years required above; and complying with the requirements

## 5.5 FORM FIN – 3.2

### Average Annual Construction Turnover

Tenderer's Name: \_\_\_\_\_ Date: \_\_\_\_\_ JV Member's Name \_\_\_\_\_  
 \_\_\_\_\_ ITT No. and title: \_\_\_\_\_

Annual turnover data (construction only)			
	Amount Currency		
[indicate year] Year	[insert amount and indicate currency]	Exchange rate	Kenya Shilling equivalent
Average Annual Construction Turnover *			

\* See Section III, Evaluation and Qualification Criteria, Sub-Factor 3.2.

<sup>1</sup> If the most recent set of financial statements is for a period earlier than 12 months from the date of Tender, the reason for this should be justified.

## Financial Resources

Specify proposed sources of financing, such as liquid assets, unencumbered real assets, lines of credit, and other financial means, net of current commitments, available to meet the total construction cash flow demands of the subject contract or contracts as specified in Section III, Evaluation and Qualification Criteria

<b>Financial Resources</b>		
<b>No.</b>	<b>Source of financing</b>	<b>Amount (Kenya Shilling equivalent)</b>
1		
2		
3		

### FORMFIN – 3.4:

#### Current Contract Commitments / Works in Progress

Tenderers and each member to a JV should provide information on their current commitments on all contracts that have been awarded, or for which a letter of intent or acceptance has been received, or for contracts approaching completion, but for which an unqualified, full completion certificate has yet to be issued.

#### ***Current Contract Commitments***

<b>No.</b>	<b>Name of Contract</b>	<b>Procuring Entity's Contact Address, Tel,</b>	<b>Value of Outstanding Work [Current Kenya Shilling /month Equivalent]</b>	<b>Estimated Completion Date</b>	<b>Average Monthly Invoicing Over Last Six Months [Kenya Shilling /month]</b>
1					
2					
3					
4					
5					

General Construction Experience

Tenderer's Name: \_\_\_\_\_ Date: \_\_\_\_\_ JV Member's Name \_\_\_\_\_  
IT No. and title: \_\_\_\_\_

Page \_\_\_\_\_ of \_\_\_\_\_ pages

Starting Year	Ending Year	Contract Identification	Role of Tenderer
		Contract name: _____ Brief Description of the Works performed by the Tenderer: _____ <del>Name of Procuring</del> Entity: _____  Address: _____	
		Contract name: _____ Brief Description of the Works performed by the Tenderer: _____ <del>Name of Procuring</del> Entity: _____ Amount of contract: _____  Address: _____	
		Contract name: _____ Brief Description of the Works performed by the Tenderer: _____ <del>Name of Procuring</del> Entity: _____  Amount of contract: _____  Address: _____	

**FORM EXP - 4.2(a)**

Specific Construction and Contract Management Experience

Tenderer's Name: \_\_\_\_\_ Date: \_\_\_\_\_ JV Member's Name \_\_\_\_\_ ITT No. \_\_\_\_\_  
and title: \_\_\_\_\_

Completion date				
Role in Contract	Prime Contractor <input type="checkbox"/>	Member in JV <input type="checkbox"/>	Management Contractor <input type="checkbox"/>	Sub-contractor <input type="checkbox"/>
Total Contract Amount			<b>Kenya Shilling</b>	
If member in a JV or sub-contractor, specify participation in total Contract amount				
Procuring Entity's Name:				
Telephone/fax number				
E-mail:				
Description of the similarity in accordance with Sub-Factor 4.2(a) of Section III:				

1.

Amount				
2.	Physical size of required works items			
3.	Complexity			
4.	Methods/Technology			
5.	Construction rate for key activities			
6.	Other Characteristics			

**FORM EXP- 4.2(b)**

Construction Experience in Key Activities

Tenderer's Name: \_\_\_\_\_ Date: \_\_\_\_\_ Tenderer's JV Member

Name: \_\_\_\_\_ Sub-contractor's Name<sup>2</sup> (as per ITT 34): \_\_\_\_\_

ITT No. and title: \_\_\_\_\_

All Sub-contractors for key activities must complete the information in this form as per ITT 34 and Section III, Evaluation and Qualification Criteria, Sub-Factor 4.2.

KeyActivity No One: -

Contract Identification		<b>Information</b>		
Award date				
Completion date				
Role in Contract				
Total Contract Amount	Prime Contractor <input type="checkbox"/>	Member in JV <input type="checkbox"/>	Management Contractor <input type="checkbox"/>	Sub-contractor <input type="checkbox"/>
	Quantity (Volume, number or rate of production, as applicable) performed under the contract per year or part of the year		Percentage participation Kenya (ii)	Actual Quantity Performed (i) x (ii)
Year 1	(i)			
Year 2				
Year 3				
Year 4				
Year				
Procuring Entity's Name:				
Address:				
Telephone/fax number				
E-mail:				
Description of the key activities in accordance with Sub-Factor 4.2(b) of Section III:				

Activity No. Two 3. ....

<sup>2</sup>If applicable

OTHER FORMS

**FORM OF TENDER**

*Tenderer must complete and sign CERTIFICATE OF INDEPENDENT TENDER DETERMINATION and the SELF DECLARATION OF THE TENDERER attached to this Form of Tender.*

**Date of this Tender submission:** .....

**Request for Tender No.:** .....

**Name and description of Tender** .....

**To:** .....

.....

Dear Sir,

In accordance with the Conditions of Contract, Specifications, Drawings and Bills of Quantities for the execution of the above-named Works, we, the undersigned offer to construct and complete the Works and remedy any defects there in for the sum<sup>3</sup> of Kenya Shillings [*Amount in figures*]\_\_\_\_\_ Kenya Shillings [*amount in words*]\_\_\_\_\_

We undertake, if our tender is accepted, to commence the Works as soon as is reasonably possible after the receipt of the Architect notice to commence, and to complete the whole of the Works comprised in the Contract within the time stated in the Special Conditions of Contract.

We agree to adhere by this tender until\_\_\_\_\_ and it shall remain binding upon us and may be accepted at any time before that date.

We understand that you are not bound to accept the lowest or any tender you may receive.

We, the under signed, further declare that:

No reservations: We have examined and have no reservations to the tender document, including Addenda issued in accordance with ITT 28;

Eligibility: We meet the eligibility requirements and have no conflict of interest in accordance with ITT 3 &4

Tender - Securing Declaration: We have not been suspended nor declared ineligible by the Procuring Entity based on execution of a Tender-Securing or Proposal-Securing Declaration in the Procuring Entity's Country in accordance with ITT 19.8;

Conformity: We offer to execute in conformity with the tendering documents and in accordance with the implementation and completion specified in the construction schedule, the following Works.....

Tender Validity Period: Our Tender shall be valid for the period specified in TDS 18.1 (as amended, if applicable) from the date fixed for the Tender submission deadline specified in TDS 22.1 (as amended, if applicable), and it shall remain binding upon us and may be accepted at any time before the expiration of that period;

Performance Security: If our Tender is accepted, we commit to obtain a Performance Security in accordance with the Tendering document;

One Tender Per Tender: We are not submitting any other Tender(s) as an individual Tender, and we are not participating in any other Tender(s) as a Joint Venture member or as a sub-contractor, and meet the requirements of ITT 3.4, other than alternative Tenders submitted in accordance with ITT 13.3;

Suspension and Debarment: We, along with any of our subcontractors, suppliers, Engineer, manufacturers,

or service providers for any part of the contract, are not subject to, and not controlled by any entity or individual that is subject to, a temporary suspension or a debarment imposed by the Public Procurement Regulatory Authority or any other entity of the Government of Kenya, or any international organization.

Binding Contract: We understand that this Tender, together with your written acceptance thereof included in your Letter of Acceptance, shall constitute a binding contract between us, until a formal contract is prepared and executed;

Not Bound to Accept: We understand that you are not bound to accept the lowest evaluated cost Tender, the Most Advantageous Tender or any other Tender that you may receive;

Fraud and Corruption: We here by certify that we have taken steps to ensure that no person acting for us or on our behalf engages in any type of Fraud and Corruption; and

Collusive practices: We hereby certify and confirm that the tender is genuine, non-collusive and made with the intention of accepting the contract if awarded. To this effect we have signed the “Certificate of Independent Tender Determination” attached below.

We undertake to adhere by the Code of Ethics for Persons Participating in Public Procurement and Asset Disposal, copy available from [www.ppra.go.ke](http://www.ppra.go.ke) during the procurement process and the execution of any resulting contract.

We, the Tenderer, have completed fully and signed the following Forms as part of our Tender:

Tenderer's Eligibility; Confidential Business Questionnaire - to establish we are not in any conflict to interest.

(b) Certificate of Independent Tender Determination - to declare that we completed the tender without colluding with other tenderers.

(a) Self-Declaration of the Tenderer - to declare that we will, if awarded a contract, not engage in any form of fraud and corruption.

Declaration and commitment to the Code of Ethics for Persons Participating in Public Procurement and Asset Disposal.

Further, we confirm that we have read and understood the full content and scope of fraud and corruption as informed in “**Appendix 1 - Fraud and Corruption**” attached to the Form of Tender.

**Name of the Tenderer:**  
.....

**Name of the person duly authorized to sign the Tender on behalf of the Tenderer:**  
.....

**Title of the person signing the Tender:**  
.....

**Signature of the person named above:**  
.....

**Date signed** .....

## TENDERER'S ELIGIBILITY- CONFIDENTIALBUSINESS QUESTIONNAIRE

Instruction to Tenderer

Tender is instructed to complete the particulars required in this Form, *one form for each entity if Tender is a JV*. Tenderer is further reminded that it is an offence to give false information on this Form.

(a) Tenderer's details

	ITEM	DESCRIPTION
1	Name of the Procuring Entity	
2	Reference Number of the Tender	
3	Date and Time of Tender Opening	
4	Name of the Tenderer	
5	Full Address and Contact Details of the Tenderer.	1. Country 2. City 3. Location 4. Building 5. Floor 6. Postal Address 7. Name and email of contact person.
6	Current Trade License Registration Number and Expiring date	
7	Name, country and full address ( <i>postal and physical addresses, email, and telephone number</i> ) of Registering Body/Agency	
8	Description of Nature of Business	
9	Maximum value of business which the Tenderer handles.	
10	State if Tenders Company is listed in stock exchange, give name and full address ( <i>postal and physical addresses, email, and telephone number</i> ) of state which stock exchange	

**General and Specific Details**

**Sole Proprietor**, provide the following details.

Name in full \_\_\_\_\_ Age \_\_\_\_\_ Nationality \_\_\_\_\_  
\_\_\_\_\_ Country of Origin \_\_\_\_\_ Citizenship \_\_\_\_\_  
\_\_\_\_\_

**Partnership**, provide the following details.

	<b>Names of Partners</b>	<b>Nationality</b>	<b>Citizenship</b>	<b>% Shares owned</b>
1				
2				
3				

**Registered Company**, provide the following details.

Private or public Company \_\_\_\_\_

State the nominal and issued capital of the Company \_\_\_\_\_

Nominal Kenya Shillings (Equivalent) ..... Issued Kenya

Shillings (Equivalent).....

Give details of Directors as follows.

	<b>Names of Director</b>	<b>Nationality</b>	<b>Citizenship</b>	<b>% Shares owned</b>
1				
2				
3				

**DISCLOSURE OF INTEREST**- Interest of the Firm in the Procuring Entity.

Are there any person/persons in ..... (*Name of Procuring Entity*) who has/have an interest or relationship in this firm? Yes/No..... If yes,

provide details as follows.

	<b>Names of Person</b>	<b>Designation in the Procuring Entity</b>	<b>Interest or Relationship with Tenderer</b>
1			
2			
3			

Conflict of interest disclosure

	Type of Conflict	Disclosure YES OR NO	If YES provide details of the relationship with Tenderer
1	Tenderer is directly or indirectly controlling, is controlled by or is under common control with another tenderer.		
2	Tenderer receives or has received any direct or indirect subsidy from another tenderer.		
3	Tenderer has the same legal representative as another tenderer		
4	Tenderer has a relationship with another tenderer, directly or through common third parties, that puts it in a position to influence the tender of another tenderer, or influence the decisions of the Procuring Entity regarding this tendering process.		
5	Any of the Tenderer's affiliates participated as a consultant in the preparation of the design or technical specifications of the works that are the subject of the tender.		
6	Tenderer would be providing goods, works, non-consulting services or consulting services during implementation of the contract Specified in this Tender Document.		
7	Tenderer has a close business or family relationship with a professional staff of the Procuring Entity who are directly or indirectly involved in the preparation of the Tender document or specifications of the Contract, and/or the Tender evaluation process of such contract.		
8	Tenderer has a close business or family relationship with a professional staff of the Procuring Entity who would be involved in the implementation or supervision of the such contract.		
9	Has the conflict stemming from such relationship stated in item 7 and 8 above been resolved in a manner acceptable to the Procuring Entity throughout the tendering process and execution of the Contract.		

**f) Certification**

On behalf of the Tenderer, I certify that the information given above is complete, current and accurate as at the date of submission.

Full Name \_\_\_\_\_

Title / Designation \_\_\_\_\_

\_\_\_\_\_  
(Signature)

\_\_\_\_\_  
(Date)

**CERTIFICATE OF INDEPENDENT TENDER DETERMINATION**

I, the undersigned, in submitting the accompanying Letter of Tender to the **Kisumu Central**

**National Government Constituency Development Fund** for:.....

.....[Name and number of tender] in response to the request for tenders made by:.....[Name of Tenderer]

do hereby make the following statements that I certify to be true and complete in every respect:

I certify, on behalf of.....[Name of Tenderer]that:

I have read and I understand the contents of this Certificate;

I understand that the Tender will be disqualified if this Certificate is found not to be true and complete in every respect;

I am the authorized representative of the Tenderer with authority to sign this Certificate, and to submit the Tender on behalf of the Tenderer;

For the purposes of this Certificate and the Tender, I understand that the word “competitor” shall include any individual or organization, other than the Tenderer, whether or not affiliated with the Tenderer, who:

Has been requested to submit a Tender in response to this request for tenders; could potentially submit a tender in response to this request for tenders, based on their qualifications, abilities or experience;

The Tenderer discloses that [check one of the following, as applicable]:

The Tenderer has arrived at the Tender independently from, and without consultation, communication, agreement or arrangement with, any competitor;

The Tenderer has entered into consultations, communications, agreements or arrangements with one or more competitors regarding this request for tenders, and the Tenderer discloses, in the attached document(s), complete details thereof, including the names of the competitors and the nature of, and reasons for, such consultations, communications, agreements or arrangements;

In particular, without limiting the generality of paragraphs (5)(a) or(5)(b) above, there has been no consultation, communication, agreement or arrangement with any competitor regarding:

- prices;
- methods, factors or formulas used to calculate prices;
- the intention or decision to submit, or not to submit, a tender; or
- the submission of a tender which does not meet the specifications of the request for Tenders; except as specifically disclosed pursuant to paragraph (5)(b) above;

In addition, there has been no consultation, communication, agreement or arrangement with any competitor regarding the quality, quantity, specifications or delivery particulars of the works or services to which this request for tenders relates, except as specifically authorized by the procuring authority or as specifically disclosed pursuant to paragraph (5)(b) above;

The terms of the Tender have not been, and will not be, knowingly disclosed by the Tenderer, directly or indirectly, to any competitor, prior to the date and time of the official tender opening, or of the awarding of the Contract, whichever comes first, unless otherwise required by law or as specifically disclosed pursuant to paragraph (5)(b) above.

Name.....

Title.....

Date.....

*[Name, title and signature of authorized agent of Tenderer and Date]*

SELF - DECLARATION FORMS

**FORM SD1**

***SELF DECLARATION THAT THE PERSON/TENDERER IS NOT DEBARRED IN THE MATTER OF THE PUBLIC PROCUREMENT AND ASSET DISPOSAL ACT 2015.***

I, .....of Post Office Box  
..... being a resident of..... in the Republic of do hereby  
make a  
statement as follows: -

THAT I am the Company Secretary/ Chief Executive/Managing Director/Principal Officer/Director of  
.....(*Insert name of the Company*) who  
is a Bidder in respect of **Tender No.....** for .....  
.....for ***Kisumu Central National Government Constituency  
Development Fund*** and duly authorized and competent to make this statement.

THAT the aforesaid Bidder, its directors and subcontractors have not been debarred from participating in  
procurement proceeding under Part IV of the Act.

THAT what is deponed to here in above is true to the best of my knowledge, information and belief.

.....  
..... (Title)

(Signature

) (Date)

Bidder Official Stamp

FORM SD2

**SELF DECLARATION THAT THE PERSON/TENDERER WILL NOT ENGAGE IN ANY CORRUPT OR FRAUDULENT PRACTICE.**

I,.....of Post Office Box  
..... being a resident of.....in the Republic of  
.....do hereby make a statement as follows: -

THAT I am the Company Secretary/ Chief Executive/Managing Director/Principal Officer/Director of  
*(Insert name of the Company)*

who is a Bidder in respect of **Tender No.....** for .....  
..... for ***Kisumu Central National Government  
Constituency Development Fund and duly authorized and competent to make this statement.***

THAT the a fore said Bidder, its servants and/or agents/subcontractors will not engage in any corrupt or fraudulent practice and has not been requested to pay any inducement to any member of the Board, Management, Staff and/or employees and/or agents of ***Kisumu Central National Government Constituency Development Fund*** which is the procuring entity.

THAT the aforesaid Bidder, its servants and/or agents /subcontractors have not offered any inducement to any member of the Board, Management, Staff and/or employees and/or agents of ***Kisumu Central National Government Constituency Development Fund***

THAT the aforesaid Bidder will not engage /has not engaged in any corrosive practice with other bidders participating in the subject tender

THAT what is deponed to here in above is true to the best of my knowledge information and belief.

.....  
(Title) (Signature) (Date)

Bidder's Official Stamp

***DECLARATION AND COMMITMENT TO THE CODE OF ETHICS***

I ..... (person) on behalf of .....  
..... ***(Name of the Business/ Company/Firm)***

declare that I have read and fully understood the contents of the Public Procurement & Asset Disposal Act, 2015, Regulations and the Code of Ethics for persons participating in Public Procurement and Asset Disposal and my responsibilities under the Code.

I do here by commit to abide by the provisions of the Code of Ethics for persons participating in Public Procurement and Asset Disposal.

Name of Authorized signatory.....

Sign.....

Position.....

Office address..... Telephone.....

E-mail.....

Name of the Firm/Company.....

Date.....

(Company Seal/ Rubber Stamp where applicable) Witness

Name.....

Sign.....

Date.....

## APPENDIX 1- FRAUD AND CORRUPTION

### Purpose

The Government of Kenya's Anti-Corruption and Economic Crime laws and their sanction's policies and procedures, Public Procurement and Asset Disposal Act (*no. 33 of 2015*) and its Regulation, and any other Kenya's Acts or Regulations related to Fraud and Corruption, and similar offences, shall apply with respect to Public Procurement Processes and Contracts that are governed by the laws of Kenya.

### Requirements

The Government of Kenya requires that all parties including Procuring Entities, Tenderers, (applicants/proposers), Consultants, Contractors and Suppliers; any Sub-contractors, Sub-consultants, Service providers or Suppliers; any Agents (whether declared or not); and any of their Personnel, involved and engaged in procurement under Kenya's Laws and Regulation, observe the highest standard of ethics during the procurement process, selection and contract execution of all contracts, and refrain from Fraud and Corruption and fully comply with Kenya's laws and Regulations as per paragraphs 1.1 above.

Kenya's public procurement and asset disposal act (*no. 33 of 2015*) under Section 66 describes rules to be followed and actions to be taken in dealing with Corrupt, Coercive, Obstructive, Collusive or Fraudulent practices, and Conflicts of Interest in procurement including consequences for offences committed. A few of the provisions noted below highlight Kenya's policy of no tolerance for such practices and behavior: -

a person to whom this Act applies shall not be involved in any corrupt, coercive, obstructive, collusive or fraudulent practice; or conflicts of interest in any procurement or asset disposal proceeding;

A person referred to under subsection (1) who contravenes the provisions of that sub-section commits an offence;

Without limiting the generality of the subsection (1) and (2), the person shall be: -

disqualified from entering into a contract for a procurement or asset disposal proceeding; or

if a contract has already been entered into with the person, the contract shall be voidable;

The voiding of a contract by the procuring entity under subsection (7) does not limit any legal remedy the procuring entity may have;

An employee or agent of the procuring entity or a member of the Board or committee of the procuring entity who has a conflict of interest with respect to a procurement: -

shall not take part in the procurement proceedings;

shall not, after a procurement contract has been entered into, take part in any decision relating to the procurement or contract; and

shall not be a subcontractor for the bidder to whom was awarded contract, or a member of the group of bidders to whom the contract was awarded, but the subcontractor appointed shall meet all the requirements of this Act.

An employee, agent or member described in subsection (1) who refrains from doing anything prohibited under that subsection, but for that subsection, would have been within his or her duties shall disclose the conflict of interest to the procuring entity;

If a person contravenes subsection (1) with respect to a conflict of interest described in subsection (5)(a) and the contract is awarded to the person or his relative or to another person in whom one of them had a direct or indirect pecuniary interest, the contract shall be terminated and all costs incurred by the public entity shall be made good by the awarding officer. Etc.

In compliance with Kenya's laws, regulations and policies mentioned above, the Procuring Entity:

Defines broadly, for the purposes of the above provisions, the terms set forth below as follows:

“Corrupt practice” is the offering, giving, receiving, or soliciting, directly or indirectly, of anything of value to influence improperly the actions of another party;

“Fraudulent practice” is any act or omission, including misrepresentation, that knowingly or recklessly misleads, or attempts to mislead, a party to obtain financial or other benefit or to avoid an obligation;

“Collusive practice” is an arrangement between two or more parties designed to achieve an improper purpose, including to influence improperly the actions of another party;

“Coercive practice” is impairing or harming, or threatening to impair or harm, directly or indirectly, any party or the property of the party to influence improperly the actions of a party;

“Obstructive practice” is:

deliberately destroying, falsifying, altering, or concealing of evidence material to the investigation or making false statements to investigators in order to materially impede investigation by Public Procurement Regulatory Authority (PPRA) or any other appropriate authority appointed by Government of Kenya into allegations of a corrupt, fraudulent, coercive, or collusive practice; and/or threatening, harassing, or intimidating any party to prevent it from disclosing its knowledge of matters relevant to the investigation or from pursuing the investigation; or acts intended to materially impede the exercise of the PPRA's or the appointed authority's inspection and audit rights provided for under paragraph 2.3 e. below.

Defines more specifically, in accordance with the above procurement Act provisions set forth for fraudulent and collusive practices as follows:

"Fraudulent practice" includes a misrepresentation of fact in order to influence a procurement or disposal process or the exercise of a contract to the detriment of the procuring entity or the tenderer or the contractor, and includes collusive practices amongst tenderers prior to or after tender submission designed to establish tender prices at artificial non-competitive levels and to deprive the procuring entity of the benefits of free and open competition.

Rejects a proposal for award<sup>1</sup> of a contract if PPRA determines that the firm or individual recommended for award, any of its personnel, or its agents, or its sub-consultants, sub-contractors, service providers, suppliers and/ or their employees, has, directly or indirectly, engaged in corrupt, fraudulent, collusive, coercive, or obstructive practices in competing for the contract in question;

Pursuant to the Kenya's above stated Acts and Regulations, may sanction or recommend to appropriate authority (ies) for sanctioning and debarment of a firm or individual, as applicable under the Acts and Regulations;

Requires that a clause be included in Tender documents and Request for Proposal documents requiring (i) Tenderers (applicants/proposers), Consultants, Contractors, and Suppliers, and their Sub-contractors, Sub-consultants, Service providers, Suppliers, Agents personnel, permit the PPRA or any other appropriate authority appointed by Government of Kenya to inspect<sup>2</sup> all accounts, records and other documents relating to the procurement process, selection and/or contract execution, and to have them audited by auditors appointed by the PPRA or any other appropriate authority appointed by Government of Kenya; and

Pursuant to Section 62 of the above Act, requires Applicants/Tenderers to submit along with their Applications/Tenders/Proposals a “Self-Declaration Form” as included in the procurement document declaring that they and all parties involved in the procurement process and contract execution have not engaged/will not engage in any corrupt or fraudulent practices.

7. **FORM OF TENDER SECURITY - DEMAND BANK GUARANTEE**

Beneficiary: \_\_\_\_\_  
Request for Tenders No: \_\_\_\_\_  
Date: \_\_\_\_\_  
TENDER GUARANTEE No.: \_\_\_\_\_  
Guarantor: \_\_\_\_\_

We have been informed that \_\_\_\_\_ (hereinafter called "the Applicant") has submitted or will submit to the Beneficiary its Tender (hereinafter called "the Tender") for the execution of \_\_\_\_\_ under Request for Tenders No. \_\_\_\_\_ ("the ITT").

Furthermore, we understand that, according to the Beneficiary's conditions, Tenders must be supported by a Tender guarantee.

At the request of the Applicant, we, as Guarantor, hereby irrevocably undertake to pay the Beneficiary any sum or sums not exceeding in total an amount of \_\_\_\_\_ (\_\_\_\_\_) upon receipt by us of the Beneficiary's complying demand, supported by the Beneficiary's statement, whether in the demand itself or a separate signed document accompanying or identifying the demand, stating that either the Applicant:

(a) has withdrawn its Tender during the period of Tender validity set forth in the Applicant's Letter of Tender ("the Tender Validity Period"), or any extension thereto provided by the Applicant; or

b) having been notified of the acceptance of its Tender by the Beneficiary during the Tender Validity Period or any extension thereto provided by the Applicant, (i) has failed to execute the contract agreement, or (ii) has failed to furnish the Performance.

This guarantee will expire: (a) if the Applicant is the successful Tenderer, upon our receipt of copies of the contract agreement signed by the Applicant and the Performance Security and, or (b) if the Applicant is not the successful Tenderer, upon the earlier of (i) our receipt of a copy of the Beneficiary's notification to the Applicant of the results of the Tendering process; or (ii) twenty-eight days after the end of the Tender Validity Period.

Consequently, any demand for payment under this guarantee must be received by us at the office indicated above on or before that date.

*[signature(s)]*

**FORM OF TENDER SECURITY (TENDER BOND)**

*[The Surety shall fill in this Tender Bond Form in accordance with the instructions indicated.]*

BOND NO. \_\_\_\_\_

BY THIS BOND *[name of tenderer]* as Principal (hereinafter called “the Principal”), and *[name, legal title, and address of surety]*, **authorized to transact business in** *[name of country of Procuring Entity]*, as Surety (hereinafter called “the Surety”), are held and firmly bound unto *[name of Procuring Entity]* as Obligated (hereinafter called “the Procuring Entity”) in the sum of *[amount of Bond]**[amount in words]*, for the payment of which sum, well and truly to be made, we, the said Principal and Surety, bind ourselves, our successors and assigns, jointly and severally, firmly by these presents.

WHEREAS the Principal has submitted or will submit a written Tender to the Procuring Entity dated the \_\_\_\_\_ day of \_\_\_\_\_, 20\_\_\_\_\_, for the supply of *[name of Contract]* (hereinafter called the “Tender”).

NOW, THEREFORE, THE CONDITION OF THIS OBLIGATION is such that if the principal: has withdrawn its Tender during the period of Tender validity set forth in the Principal's Letter of Tender (“the Tender Validity Period”), or any extension thereto provided by the principal; or having been notified of the acceptance of its Tender by the Procuring Entity during the Tender Validity Period or any extension thereto provided by the principal; (i) failed to execute the Contract agreement; or (ii) has failed to furnish the Performance Security, in accordance with the Instructions to tenderers (“ITT”) of the Procuring Entity's Tendering document.

Then the Surety undertakes to immediately pay to the Procuring Entity up to the above amount upon receipt of the Procuring Entity's first written demand, without the Procuring Entity having to substantiate its demand, provided that in its demand the Procuring Entity shall state that the demand arises from the occurrence of any of the above events, specifying which event(s) has occurred.

The Surety hereby agrees that its obligation will remain in full force and effect up to and including the date 30 days after the date of expiration of the Tender Validity Period set forth in the Principal's Letter of Tender or any extension thereto provided by the Principal.

IN TESTIMONY WHEREOF, the Principal and the Surety have caused these presents to be executed in their respective names this \_\_\_\_\_ day of \_\_\_\_\_ 20\_\_\_\_\_.

Principal: \_\_\_\_\_ Surety \_\_\_\_\_  
Corporate Seal (where appropriate) :

\_\_\_\_\_  
*(Signature)*

*(Printed name and title)*

\_\_\_\_\_  
*(Signature)*

*(Printed name and title)*

TENDER-SECURING DECLARATION FORM

*[The Bidder shall complete this Form in accordance with the instructions indicated]*

Date:..... *[insert date (as day, month and year) of Tender Submission]*

Tender No..... *[insert number of tendering processes]*

To:..... *[insert complete name of Purchaser]* I/We, the undersigned, declare that:

I/We understand that, according to your conditions, bids must be supported by a Tender-Securing Declaration.

I/We accept that I/we will automatically be suspended from being eligible for tendering in any contract with the Purchaser for the period of time of *[insert number of months or years]* starting on *[insert date]*, if we are in breach of our obligation(s) under the bid conditions, because we – (a) have withdrawn our tender during the period of tender validity specified by us in the Tendering Data Sheet; or (b) having been notified of the acceptance of our Bid by the Purchaser during the period of bid validity, (i) fail or refuse to execute the Contract, if required, or (ii) fail or refuse to furnish the Performance Security, in accordance with the instructions to tenders.

I/We understand that this Tender Securing Declaration shall expire if we are not the successful Tenderer(s), upon the earlier of:

our receipt of a copy of your notification of the name of the successful Tenderer; or  
thirty days after the expiration of our Tender.

I/We understand that if I am/we are/in a Joint Venture, the Tender Securing Declaration must be in the name of the Joint Venture that submits the bid, and the Joint Venture has not been legally constituted at the time of bidding, the Tender Securing Declaration shall be in the names of all future partners as named in the letter of intent.

Signed... ..Capacity / title (director or partner or sole proprietor, etc.) .....Name:

..... Duly authorized to sign the bid for

and on behalf of: *[insert complete name of Tenderer]*

Dated on ..... day of..... *[Insert date of signing]* Seal or stamp

---

## **PART II - WORK REQUIREMENTS**

---

## SECTION V - DRAWINGS

A list of drawings should be inserted here. The actual drawings including Site plans should be annexed in a separate booklet.

## SECTION VI - SPECIFICATIONS

Notes for preparing Specifications

Specifications must be drafted to present a clear and precise statement of the required standards of materials, and workmanship for tenderers to respond realistically and competitively to the requirements of the Procuring Entity and ensure responsiveness of tenders. The Specifications should require that all materials, plant, and other supplies to be permanently incorporated in the Works be new, unused, of the most recent or current models, and incorporating all recent improvements in design and materials unless provided otherwise in the Contract. Where the Contractor is responsible for the design of any part of the permanent Works, the extent of his obligations must be stated.

Specifications from previous similar projects are useful and may not be necessary to re-write specifications for every Works Contract.

There are considerable advantages in standardizing **General Specifications** for repetitive Works in recognized public sectors, such as highways, urban housing, irrigation and water supply. The General Specifications should cover all classes of workmanship, materials and equipment commonly involved in constructions, although not necessarily to be used in a particular works contract. Deletions or addenda should then adapt the General Specifications to the particular Works.

Care must be taken in drafting Specifications to ensure they are not restrictive. In the Specifications of standards for materials, plant and workmanship, existing Kenya Standards should be used as much as possible, otherwise recognized international standards may also be used.

The Procuring Entity should decide whether technical solutions to specified parts of the Works are to be permitted. Alternatives are appropriate in cases where obvious (and potentially less costly) alternatives are possible to the technical solutions indicated in tender documents for certain elements of the Works, taking into consideration the comparative specialized advantage of potential tenderers.

The Procuring Entity should provide a description of the selected parts of the Works with appropriate reference to Drawings, Specifications, Bills of Quantities, and Design or Performance criteria, stating that the alternative solutions shall be at least structurally and functionally equivalent to the basic design parameters and Specifications.

Such alternative solutions shall be accompanied by all information necessary for a complete evaluation by the Procuring Entity, including drawings, design calculations, technical specifications, breakdown of prices, proposed construction methodology, and other relevant details. Technical alternatives permitted in this manner shall be considered by the Procuring Entity each on its own merits and independently of whether the tenderer has priced the item as described in the Procuring Entity's design included with the tender documents.

## **SECTION VII- BILLS OF QUANTITIES**

### Objectives

The objectives of the Bill of Quantities are:

to provide sufficient information on the quantities of Works to be performed to enable tenders to be prepared efficiently and accurately; and  
when a Contract has been entered into, to provide a priced Bill of Quantities for use in the periodic valuation of Works executed.

In order to attain these objectives, Works should be itemized in the Bill of Quantities in sufficient detail to distinguish between the different classes of Works, or between Works of the same nature carried out in different locations or in other circumstances which may give rise to different considerations of cost. Consistent with these requirements, the layout and contents of the Bill of Quantities should be as simple and brief as possible.

### Provisional Sums

A general provision for physical contingencies (quantity overruns) may be made by including a provisional sum in the Summary Bill of Quantities. Similarly, a contingency allowance for possible price increases should be provided as a provisional sum in the Summary priced Bill of Quantities. The inclusion of such provisional sums often facilitates budgetary approval by avoiding the need to request periodic supplementary approvals as the future need arises. Where such provisional sums or contingency allowances are used, the Special Conditions of Contract should state the manner in which they shall be used, and under whose authority (usually the Project Manager's).

The estimated cost of specialized work to be carried out, or of special goods to be supplied, by other contractors should be indicated in the relevant part of the Bill of Quantities as a particular provisional sum with an appropriate brief description. A separate procurement procedure is normally carried out by the Procuring Entity to select such specialized contractors. To provide an element of competition among the Tenderers in respect of any facilities, amenities, attendance, etc., to be provided by the successful Tenderer as prime Contractor for the use and convenience of the specialist contractors, each related provisional sum should be followed by an item in the Bill of Quantities inviting the Tenderer to quote a sum for such amenities, facilities, attendance, etc.

These Notes for Preparing a Bill of Quantities are intended only as information for the Procuring Entity or the person drafting the tendering document. They should not be included in the final tendering document.

### The Bills of Quantities

The Bills of Quantities should be divided generally into the following sections:

Preambles

Preliminary items

Work Items

Daywork Schedule;and

Provisional items

Summary.



**REPUBLIC OF KENYA**



**NATIONAL GOVERNMENT CONSTITUENCY DEVELOPMENT FUND**

**KISUMU CENTRAL CONSTITUENCY**

**BILL OF QUANTITIES**

**FOR**

**PROPOSED CONSTRUCTION TO COMPLETION OF 45 CAPACITY  
SCIENCE LABORATORY**

**AT**

**ST. PETER'S NANGA SECONDARY SCHOOL**

**IN**

---

**KISUMU CENTRAL CONSTITUENCY**

---

**PROJECT MANAGER  
DEPARTMENT OF PUBLIC WORKS  
P.O. BOX 821 - 40100  
KISUMU**

---

**JULY 2024.**

# **BILL OF QUANTITIES**

ITEM NO.	DESCRIPTION	UNIT	QTY	RATE	KSHS.	CTS
1	<p><b><u>PROPOSED CONSTRUCTION OF 45 STUDENTS CAPACITY LABORATORY AT ST.PETER NANGA SECONDARY SCHOOL</u></b>  <b><u>BILLS OF QUANTITIES</u></b></p> <p><b><u>SECTION NO. 2</u></b></p> <p><b><u>ELEMENT NO.1</u></b></p> <p><b><u>SUBSTRUCTURE</u></b></p> <p>(All Provisional)</p> <p><b><u>NOTES</u></b></p> <p>The Tenderer's attention is drawn to the Preliminaries Contract Particulars Clause 8.0 which states that the Standard Method of Measurement is the June 2008 Edition. Per Clause D5(g) of this S.M.M <b>all excavations in this BoQ have been measured NET and no allowance has been made for working space and the tenderer is shall price for the excavations accordingly.</b></p> <p>Cement for all Structural Works in these Bills of Quantities shall strictly be <b>Grade 32.5</b></p> <p>Cement for Non-Structural Works in these Bills of Quantities shall be <b>Grade 32.5</b></p> <p>All Reinforcement in these Bills of Quantities shall be to BS 4449:1997 with the following characteristic; a) <b>Grade 460 B high strength type 2 Ribbed bars with proof stress of 460N/mm<sup>2</sup></b>; allow for cutting, bending, hoisting and fixing including all necessary trying wires and spacer stools;</p>					

ITEM NO.	DESCRIPTION	UNIT	QTY	RATE	KSHS.	CTS
	<u>SUBSTRUCTURES (CONT'D)</u>					
	<u>Excavations &amp; Earthworks</u>					
A	Excavate to remove top vegetable soil average 150mm deep; remove from site	m2	162			
B	Excavate to reduce levels, not exceeding 1.5 m deep from stripped level	m3	28			
C	Excavate for strip foundations not exceeding 1.5 m deep from reduced level	m3	19			
D	Ditto for Column Bases not exceeding 1.5 m deep from reduced level	m3	11			
E	Allow for keeping excavations free from water by baling or pumping as required including provision of drains, etc., as described	Item				
F	Allow for maintaining and supporting sides of excavations and for keeping free from fallen materials as described	Item				
	<u>Disposal</u>					
G	Backfilling around foundations & columns	m3	21			
H	Load and cart away surplus spoil	m3	52			
	<u>Imported filling</u>					
I	300mm Thick approved hardcore under floor bed well compacted	m2	162			
J	40mm Thick Murram or quarry dust blinding to hardcore	m2	162			
	<u>Carried to Collection</u>					
				Kshs.		

ITEM NO.	DESCRIPTION	UNIT	QTY	RATE	KSHS.	CTS
	<b>SUBSTRUCTURES (CONT'D)</b>					
	<u>Damp proof membrane as described :-</u>					
A	1000 Gauge polythene sheet dampproof membrane to horizontal surfaces	m2	162			
	<u>Anti-termite treatment</u>					
B	Chemical anti-termite treatment executed by an approved specialist under a ten-year guarantee to horizontal surfaces of the floor slab and around the plinth, e.t.c.	m2	162			
	<u>Concrete Class ( 1:3:6 ) in 50mm thick blinding under :-</u>					
C	Strip foundations for masonry walling	m2	42			
D	Column bases	m2	15			
	<u>Vibrated reinforced concrete class 25 in:</u>					
E	Colum Bases	m3	4			
F	Columns	m3	2			
G	Strip foundations	m3	6			
H	150 mm Thick slab	m2	162			
	<b><u>Reinforcement</u></b>					
	<u>Reinforcement to BS 4449:1997 with the following characteristic; a) Grade 460 B high strength type 2 Ribbed bars with proof stress of 460N/mm<sup>2</sup>; allow for cutting, bending, hoisting and fixing including all necessary trying wires and spacer stools</u>					
I	Assorted Bars	Kg	1,171			
	<u>Carried to Collection</u>				Kshs.	

ITEM NO.	DESCRIPTION	UNIT	QTY	RATE	KSHS.	CTS
	<u>SUBSTRUCTURES (CONT'D)</u>					
	<u>Steel mesh fabric reinforcement to B.S. 4483</u>					
A	Ref. A142 Layer of fabric mesh reinforcement laid in bed with 150mm side and end laps	m2	162			
	<u>Sawn formwork to:</u>					
B	Sides of column bases	m2	27			
C	Sides of column	m2	21			
D	Sides of strip foundations	m2	36			
E	Edges of floor beds 150 - 225mm high	m	68			
	<u>Quarry dressed natural stone walling in cement sand mortar (1:3) with minimum crushing strength of 7.0 N/mm<sup>2</sup></u>					
F	200mm Thick walling	m2	110			
	<u>1000 Gauge polythene sheet damp proof course laid on and including cement sand (1:3) levelling screed</u>					
G	200mm Wide	m	98			
	<u>Cement sand ( 1:4 ) render to :-</u>					
H	12mm Thick render to wall externally	m2	14			
	<u>Prepare and apply two coats of bituminous paint to :-</u>					
I	Rendered walls externally	m2	14			
	<u>Carried to Collection</u>				Kshs.	

ITEM NO.	DESCRIPTION	UNIT	QTY	RATE	KSHS.	CTS
	<p style="text-align: center;"><u>COLLECTION</u></p> <p style="text-align: center;">Page No. 2/2</p> <p style="text-align: center;">Page No. 2/3</p> <p style="text-align: center;">Page No. 2/4</p>					
	<p><b><u>TOTAL FOR SUBSTRUCTURES CARRIED TO SUMMARY</u></b></p>			<p style="text-align: center;"><b>KSHS.</b></p>		

ITEM NO.	DESCRIPTION	UNIT	QTY	RATE	KSHS.	CTS.
	<b><u>PROPOSED CONSTRUCTION OF 45 STUDENTS CAPACITY LABORATORY AT BILLS OF QUANTITIES SECTION NO. 2</u></b>					
	<b><u>ELEMENT NO.2</u></b>					
	<b><u>RC SUPERSTRUCTURE</u></b>					
	<u>Concrete Class 25mm in:-</u>					
A	Columns	m3	6			
B	100mm worktop slab	m2	68			
	<u>Concrete Class 25mm in:-</u>					
C	Ring beams	m3	5			
	<b><u>Reinforcement: as before described</u></b>					
D	8mm diameter bars	Kg	275			
E	10mm diameter bars	Kg	321			
F	12mm diameter bars	Kg	211			
G	16mm diameter bars	Kg	310			
	<b><u>Steel fabric mesh reinforcement to B.S.4483 to Worktop slab</u></b>					
H	BRC mesh fabric reinforcement ref A142( weighing 2.2kg/m2) laid in ramp (measured net-no allowance made for lamps)	m2	68			
	<u>Sawn formwork to :-</u>					
I	Vertical sides of columns	m2	109			
J	Sides and soffites of ringbeams	m2	78			
K	Sides and soffites of Worktops	m2	68			
L	102 mm diameter x 3 mm thick CHS columns in 6 NO exceeding 5 kg/m but not exceeding 10 kg/m welded and bolted to cap and base plates (7.33 kg/m)	KG	148			
	<b><u>TOTAL FOR RC SUPERSTRUCTURE CARRIED TO SUMMARY</u></b>					

ITEM NO.	DESCRIPTION	UNIT	QTY	RATE	KSHS.	CTS.
	<p><b><u>PROPOSED CONSTRUCTION OF 45 STUDENTS CAPACITY LABORATORY AT</u></b>  <b><u>BILLS OF QUANTITIES</u></b></p> <p><b><u>SECTION NO. 2</u></b></p> <p><b><u>ELEMENT NO.4</u></b></p> <p><b><u>ROOF CONSTRUCTION, COVERINGS AND RAINWATER DISPOSAL</u></b></p> <p><b><u>ROOF CONSTRUCTION</u></b></p> <p><u>The following in sawn softwood timber including fabricating, hoisting and fixing in position approximately 12,000mm above ground floor level as per Structural Engineer's drawing</u></p> <p><u>Sawn cypress</u></p> <p><u>Rates to include all necessary bolting and/or nailing</u></p>					
A	100 x 100 mm rafters	m	278			
B	100 x 75 mm Tie beams	m	112			
C	150 x 100 mm Wall plate	m	78			
D	75 x 50 mm Purlins	m	247			
E	75 x 50 mm Struts & Ties	m	329			
	<u>Carried to Collection</u>			Kshs.		

ITEM NO.	DESCRIPTION	UNIT	QTY	RATE	KSHS.	CTS.
	<u>ROOF(CONT'D)</u>					
	<u>Wrot treated prime grade cypress</u>					
A	38mm thick tongued and grooved eaves filling V-jointed and secretly nailed onto and including 50mm x 50mm sawn cypress brackets with mosquito wire gauze in between	m	56			
B	225mm x 38mm thick fascia board fixed onto ends of rafters	m	56			
	<u>ROOF COVERINGS</u>					
C	Roof covering as 28 gauge roofing Sheet including roof vents to suppliers recommendations	m2	210			
D	ridge board to match roof sheet	m	16			
E	600 mm wide ditto valley flashing four times bent	m	12			
F	Extra over roofing sheet for raking cutting	m	9			
	<u>Prepare surfaces and apply one coat of aluminium wood primer and two finishing coats of gloss oil paint on:</u>					
G	General wood surfaces	m	56			
H	Wood surfaces 200 - 300mm girth	m	8			
	<u>Carried to Collection</u>				Kshs.	

ITEM NO.	DESCRIPTION	UNIT	QTY	RATE	KSHS.	CTS.
	<u>ROOF(CONT'D)</u>					
	<u>Rainwater goods</u>					
A	200mm wide x 200mm deep (600mm girth ) prepainted gauge 24 galvanised iron gutter fixed onto fascia board with approved mild steel straps at every 1,000mm centres	m	32			
B	Extra over ditto for stopped ends	No.	4			
C	Ditto for forming 150mm x 150mm hole for down pipe	No.	6			
D	150mm x 150mm prepainted gauge 24 galvanised iron rain water down pipe fixed onto walls with approved mild steel support brackets at 1,000mm centres	m	12			
	<u>Carried to Collection</u>			Kshs.		

ITEM NO.	DESCRIPTION	UNIT	QTY	RATE	KSHS.	CTS.
	<u>(ROOF CONT'D)</u>					
	<u>COLLECTION</u>					
	Page No. 2/1					
	Page No. 2/2					
	Page No. 2/3					
	<u>TOTAL FOR ROOF CARRIED TO SUMMARY</u>				<b>KSHS.</b>	

ITEM NO.	DESCRIPTION	UNIT	QTY.	RATE	KSHS.	CTS.
	<b><u>PROPOSED CONSTRUCTION OF 45 STUDENTS CAPACITY LABORATORY AT ST.PETER NANGA SECONDARY SCHOOL</u></b>					
	<b><u>BILLS OF QUANTITIES</u></b>					
	<b><u>SECTION NO. 2</u></b>					
	<b><u>ELEMENT NO. 5</u></b>					
	<b><u>EXTERNAL WALLS</u></b>					
	<u>Approved local natural stonework; squared and machine dressed;bedded in cement mortar (1:4); reinforced with 25mm wide x 20mm gauge hoop iron strapping every alternate course</u>					
A	200mm Thick walls	m2	216			
	<b><u>Damp proof course</u></b>					
B	200mm Wide	m	80			
	<u>Carried to Collection</u>				Kshs.	



ITEM NO.	DESCRIPTION	UNIT	QTY.	RATE	KSHS.	CTS.
	<b><u>PROPOSED CONSTRUCTION OF 45 STUDENTS CAPACITY LABORATORY AT ST.PETER NANGA SECONDARY SCHOOL</u></b>					
	<b><u>BILLS OF QUANTITIES</u></b>					
	<b><u>SECTION NO. 2</u></b>					
	<b><u>ELEMENT NO. 6</u></b>					
	<b><u>INTERNAL WALLS</u></b>					
	<u>Approved local natural stonework; squared and machine dressed;bedded in cement mortar (1:4); reinforced with 25mm wide x 20mm gauge hoop iron strapping every alternate course</u>					
A	200mm Thick walls	m2	32			
B	100mm Thick walls in worktops	m2	52			
	<b><u>Damp proof course</u></b>					
C	200mm Wide	m	12			
	<b><u>TOTAL FOR INTERNAL WALLS CARRIED TO SUMMARY</u></b>				KSHS.	

ITEM NO.	DESCRIPTION	UNIT	QTY.	RATE	KSHS.	CTS.
	<p><b><u>PROPOSED CONSTRUCTION OF 45 STUDENTS CAPACITY LABORATORY AT ST.PETER NANGA SECONDARY SCHOOL</u></b></p> <p><b><u>BILLS OF QUANTITIES</u></b></p> <p><b><u>SECTION NO. 2</u></b></p> <p><b><u>ELEMENT NO. 7</u></b></p> <p><b><u>WINDOWS</u></b></p> <p><b><u>STEEL WINDOWS</u></b></p> <p><u>Supply and fix the following purpose made casement windows comprising of 50 x 50 x 16 G and 25 mm "Z" section framing including all coupling mullions etc;and complete with bronze handles ,peg stays and other ironmongery; factory primed with red oxide primer including cutting and pinning fixing lugs to concrete or masonry work jambs ; bedding in cement and sand (1:3) mortar , pointing all round frames in mastic ,easing ,oiling and adjusting opening lights on completion, including 4 mm glazing; All as per the architect's Schedule of windows</u></p> <p>A Size 3000x 1500 mm high</p> <p>B Size 1200x 1500 mm high</p> <p><u>Carried to Collection</u></p>					
A	Size 3000x 1500 mm high	No.	4			
B	Size 1200x 1500 mm high	No.	2			
	<u>Carried to Collection</u>			Kshs.		

ITEM NO.	DESCRIPTION	UNIT	QTY.	RATE	KSHS.	CTS.
	<b><u>WINDOWS (CONT'D)</u></b>					
	<u>Precast concrete weathered and throated window cills</u>					
A	Window cill over all size 275 x 100 mm high with 3 No	m	16			
B	Prepare and apply three coats gloss paint	m2	46			
	<u>Carried to Collection</u>				Kshs.	
	<u>COLLECTION</u>					
	Page No. 2/1					
	Page No. 2/2					
	<b><u>TOTAL FOR WINDOWS CARRIED TO SUMMARY</u></b>				<b>KSHS.</b>	

ITEM NO.	DESCRIPTION	UNIT	QTY	RATE	KSHS.	CTS.
	<b><u>PROPOSED CONSTRUCTION OF 45 STUDENTS CAPACITY LABORATORY AT ST.PETER NANGA SECONDARY SCHOOL</u></b>					
	<b><u>BILLS OF QUANTITIES</u></b>					
	<b><u>SECTION NO. 2</u></b>					
	<b><u>ELEMENT NO. 8</u></b>					
	<b><u>DOORS</u></b>					
	<u>Steel Doors</u>					
	<u>Supply and fix the following steel casement door fabricated from 50mm x 25mm x 3mm thick Rectangular Hollow Section ( R.H.S) mild steel framing infilled with 14 gauge mild steel sheet factory primed in red oxide or zinc chromate primer including 6mm thick clear glass infill complete with all necessary purpose made ironmongery, and locks to Architect's details and approval</u>					
A	Size 1500 x 2400 mm high door	No.	2			
	<u>Flush Doors</u>					
	<u>45mm Thick blockboard semi -solid core flush door with hardwood lipping</u>					
B	Size 900 x 2400 mm high door	No.	2			
	<u>Frames</u>					
	<u>Sawn hardwood frame</u>					
C	150 x 30 mm Thick frames with two labours	m	18			
	<u>Grile Door</u>					
D	Size 900 x 2400 mm high door	No.	1			
	<u>Carried to Collection</u>			Kshs.		

ITEM NO.	DESCRIPTION	UNIT	QTY	RATE	KSHS.	CTS.
	<u>DOORS (CONT'D)</u>					
	<u>Ironmongery</u>					
	<u>Supply and fix the following ironmongery as applicable or equal and approved ironmongery with matching</u>					
A	100 mm Mild Steel Butt Hinges	Prs	4			
B	Two lever mortice lock including 2 No. Lever Handles	Set	2			
C	Rubber door stopper	No	4			
	<u>Painting and decorating</u>					
	<u>Touch up primer,prepare and apply three coats of gloss oil paint to</u>					
D	Metal surfaces	m2	18			
	<u>Prepare and apply three coats matt emulsion paint to</u>					
E	Timber surfaces	m2	6			
	<u>Carried to Collection</u>				Kshs.	
	<u>COLLECTION</u>					
	Page No. 2/1					
	Page No. 2/2					
	<b><u>TOTAL FOR DOORS CARRIED TO SUMMARY</u></b>				<b>KSHS.</b>	

ITEM NO.	DESCRIPTION	UNIT	QTY	RATE	KSHS.	CTS.
	<b>PROPOSED CONSTRUCTION OF 45 STUDENTS</b>					
	<b><u>CAPACITY LABORATORY AT ST.PETER NANGA SECONDARY SCHOOL</u></b>					
	<b><u>BILLS OF QUANTITIES</u></b>					
	<b><u>SECTION NO. 2</u></b>					
	<b><u>ELEMENT NO. 9</u></b>					
	<b><u>EXTERNAL FINISHES</u></b>					
	<b><u>Floor Finishes</u></b>					
	<u>Cement Sand (1:4) screed as described</u>					
A	40 mm Thick finished to receive tiles	m2	31			
	<u>Supply and fix with and including Sika Ceramic 100g grey adhesive and grouting with Sika tile grout and pointing to match. Rate to include breakage and cutting waste</u>					
B	400 x 400 mm Ceramic tiles in patterns as directed	m2	31			
C	100 mm Skirting tile <b>cut out of tiles above</b>	m	40			
	<u>Cement and sand (1:4) render</u>					
D	12mm Thick to wall ,exposed beams and columns	m2	216			
	<u>Prepare and apply two coats matt emulsion paint to</u>					
E	Plastered surfaces externally	m2	216			
	<u>Paving slab</u>					
F	600x600mm thick paving slab	m2	32			
	<u>Ramp</u>					
G	1500x2400mm Mass Concrete Ramp	No	1			
	<u>Carried to Collection</u>				Kshs.	

ITEM NO.	DESCRIPTION	UNIT	QTY	RATE	KSHS.	CTS.
	<u>EXTERNAL FINISHES (CONT'D)</u>					
	<u>Ceiling Finishes</u>					
	<u>Chipboard ceiling</u>					
A	Chipboard ceiling	m2	31			
B	Provide and fix 50x50mm cornices	m2	60			
C	Branding size 50x50mm	m2	124			
	<u>Prepare and apply two coats internal quality matt</u>					
D	soffits of chipboard	m2	31			
	<u>Carried to Collection</u>				Kshs.	
	<u>COLLECTION</u>					
	Page No. 2/1					
	Page No. 2/2					
	<u>TOTAL FOR EXTERNAL FINISHES CARRIED TO SUMMARY</u>				<b>KSHS.</b>	

ITEM NO.	DESCRIPTION	UNIT	QTY	RATE	KSHS.	CTS.
	<b><u>PROPOSED CONSTRUCTION OF 45 STUDENTS CAPACITY LABORATORY AT ST.PETER NANGA SECONDARY SCHOOL</u></b>					
	<b><u>BILLS OF QUANTITIES</u></b>					
	<b><u>SECTION NO. 2</u></b>					
	<b><u>ELEMENT NO.10</u></b>					
	<b><u>INTERNAL FINISHES</u></b>					
	<b><u>Floor Finishes</u></b>					
	<u>Cement Sand (1:4) screed as described</u>					
A	20 mm Thick finished to receive ceramic floor tiles	m2	124			
	<u>Supply and fix with and including Sika Ceramic 100g grey adhesive and grouting with Sika tile grout and pointing to match. Rate to include breakage and cutting waste</u>					
B	400 x 400 mm ceramic floor tiles in patterns as directed	m2	124			
C	Ditto 300 x 300 mm ceramic tiles in worktops	m2	68			
D	100 mm Skirting tile <b>cut out of tiles above</b>	m	79			
	<u>Cement, sand, lime (1:2:9) in :-</u>					
E	12 mm Thick plaster to masonry or concrete surfaces	m2	321			
	<u>Carried to Collection</u>				Kshs.	

ITEM NO.	DESCRIPTION	UNIT	QTY	RATE	KSHS.	CTS.
	<u>Painting and Decorating</u>					
	<u>Prepare and apply two coats internal quality matt emulsion paint to:-</u>					
A	Plastered wall surfaces	m2	321			
	<b><u>Ceiling Finishes</u></b>					
	<b><u>Chipboard ceiling</u></b>					
B	Chipboard ceiling	m2	124			
C	Provide and fix 50x50mm cornices	m2	79			
D	Branding size 50x50mm	m2	214			
E	Branding size 75x50mm	m2	243			
	<u>Prepare and apply two coats internal quality matt</u>					
F	soffits of chipboard	m2	124			
	<u>Carried to Collection</u>					
	<u>COLLECTION</u>					
	Page No. 2/1					
	Page No. 2/2					
	<b><u>TOTAL FOR INTERNAL FINISHES CARRIED TO SUMMARY</u></b>					
					<b>KSHS.</b>	

ITEM NO.			SHS.	CTS.
	<p><b><u>PROPOSED CONSTRUCTION OF 45 STUDENTS CAPACITY LABORATORY AT ST.PETER NANGA SECONDARY SCHOOL</u></b></p> <p><b><u>BILLS OF QUANTITIES</u></b></p> <p><b><u>SECTION NO. 2</u></b></p> <p><b><u>LABORATORY BLOCK</u></b></p> <p><b><u>SUMMARY</u></b></p> <p>1. SUBSTRUCTURES</p> <p>2. RC SUPERSTRUCTURE</p> <p>3. ROOF</p> <p>4. EXTERNAL WALLS</p> <p>5. INTERNAL WALLS</p> <p>6. WINDOWS</p> <p>7. DOORS</p> <p>8. EXTERNAL FINISHES</p> <p>9. INTERNAL FINISHES</p> <p><b><u>TOTAL CARRIED TO MAIN SUMMARY</u></b></p>	<p><b><u>PAGE NO.</u></b></p> <p>2/5</p> <p>2/6</p> <p>2/4</p> <p>2/15</p> <p>2/16</p> <p>2/18</p> <p>2/20</p> <p>2/22</p> <p>2/24</p> <p><b><u>KSHS.</u></b></p>		

ITEM NO.	DESCRIPTION	UNIT	QTY.	KSHS.	CTS.
	<b><u>PROPOSED CONSTRUCTION OF 45 STUDENTS CAPACITY LABORATORY AT ST.PETER NANGA SECONDARY SCHOOL</u></b>				
	<b><u>BILLS OF QUANTITIES</u></b>				
	<b><u>SECTION NO. 3</u></b>				
	<b><u>PRIME COST AND PROVISIONAL SUMS</u></b>				
	<b><u>PRIME COST SUMS</u></b>				
A	Allow a Prime Cost Sum of Kenya Shillings One Hundred and Forty Thousand for Electrical works		Sum	140,000	00
B	Allow a Prime Cost Sum of Kenya Shillings Two Hundred and Fifty Thousand for Plumbing and Fittings works		Sum	250,000	00
C	Allow a Prime Cost Sum of Kenya Shillings One Hundred Thousand for Contingency		Sum	100,000	00
D	Allow a Prime Cost Sum of Kenya Shillings One Hundred Thousand for Project Supervision, Archictural drawings,Structural drawings and Preparation of Bill of Quantity		Sum	100,000	00
E	Allow a Prime Cost Sum of Kenya Shillings Ninety Thousand for Project Committee		Sum	90,000	00
F	Allow a Prime Cost Sum of Kenya Shillings Ten Thousand for Sign board and branding the project according to CDF Specification		Sum	10,000	00
G	Allow a Prime Cost Sum of Kenya Shillings Seventy Thousand for Documentation		Sum	70,000	00
H	Allow a Prime Cost Sum of Kenya Shillings Seventy Thousand for Documentation		Sum	50,000	00
	<b><u>TOTAL FOR PRIME COST AND PROVISIONAL SUMS CARRIED TO SUMMARY</u></b>		<b>KSHS.</b>	<b>760,000</b>	<b>00</b>

ITEM NO.			SHS.	CTS.
	<b><u>PROPOSED CONSTRUCTION OF 45 STUDENTS CAPACITY LABORATORY AT ST.PETER NANGA SECONDARY SCHOOL</u></b>			
	<u>MAIN SUMMARY</u>	<u>PAGE NO.</u>		
1.	PRELIMINARIES	1/26		
2.	BUILDER'S WORKS	2/25		
3	PROVISIONAL SUMS	3/1		
	SUB-TOTAL			
	ADD 16% VAT			
	<b><u>TOTAL CARRIED TO FORM OF TENDER</u></b>	<b>KSHS.</b>		

Amount in Words Kenya Shillings.....  
.....  
.....

NAME OF TENDERER.....

ADDRESS.....

SIGNATURE..... DATE.....

WITNESS

NAME.....

ADDRESS.....

SIGNATURE.....

DATE.....

# ELEVATION 03

**GENERAL NOTES:**  
 1. All dimensions to be checked on site before commencement of any work. Use figured dimensions only. Any discrepancies should be reported to the Architect immediately.  
 2. All dimensions are in millimetres unless otherwise specified.  
 3. P.V denotes permanent vent.  
 4. Metal gutters & down pipe to suite.  
 5. All windows & doors to schedule.  
 6. All internal fittings to approval.

**CIVIL WORKS:**  
 1. All soils under slabs and around external foundations to be treated for termite control.  
 2. All soils on cut embankments to be stabilised. Slope not to exceed the natural angle of repose.  
 3. All slabs at ground level to be poured over 1000 gauge polythene sheeting on 50mm stone blinding on hardcore.

**STRUCTURAL WORKS:**  
 1. Refer to structural Engineers details for all r.c works.  
 2. Foundation depth to be determined on site to structural Engineer's approval.  
 3. All adjacent r.c work and masonry walls to be tied with strap irons at every course.

**MECHANICAL WORKS:**  
 1. All sanitary fittings, doors, windows and lifts to schedules.  
 2. All plumbing and drainage to comply with city council's specifications.  
 3. All service ducts to be accessible from every floor.

**1. FLOOR FINISHES**

**2. WALL FINISHES**

**3. CEILING FINISHES**

**4. SKIRTING FINISHES**

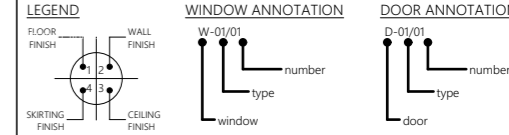

PROJECT TITLE: PROPOSED LABORATORY FOR ARINA PRIMARY SCHOOL

CLIENT: NG-CDF

LOCATION: KISUMU CENTRAL CONSTITUENCY

DRAWING SCALE: AS SHOWN

STATUS: ARCHITECTURAL DRAWINGS

**REVISIONS**

Nº	DESCRIPTION	DATE	COMMENT

**CONSULTANT**



**STATE DEPARTMENT OF PUBLIC WORKS**

JOB NUMBER: PW/1/2023

DRAWN BY: Kennedy R. Owino  
 DATE: JAN. 2023

SHEET NUMBER

# ELEVATION 04

# ELEVATION 02

# ELEVATION 01

## FLOOR LAYOUT PLAN

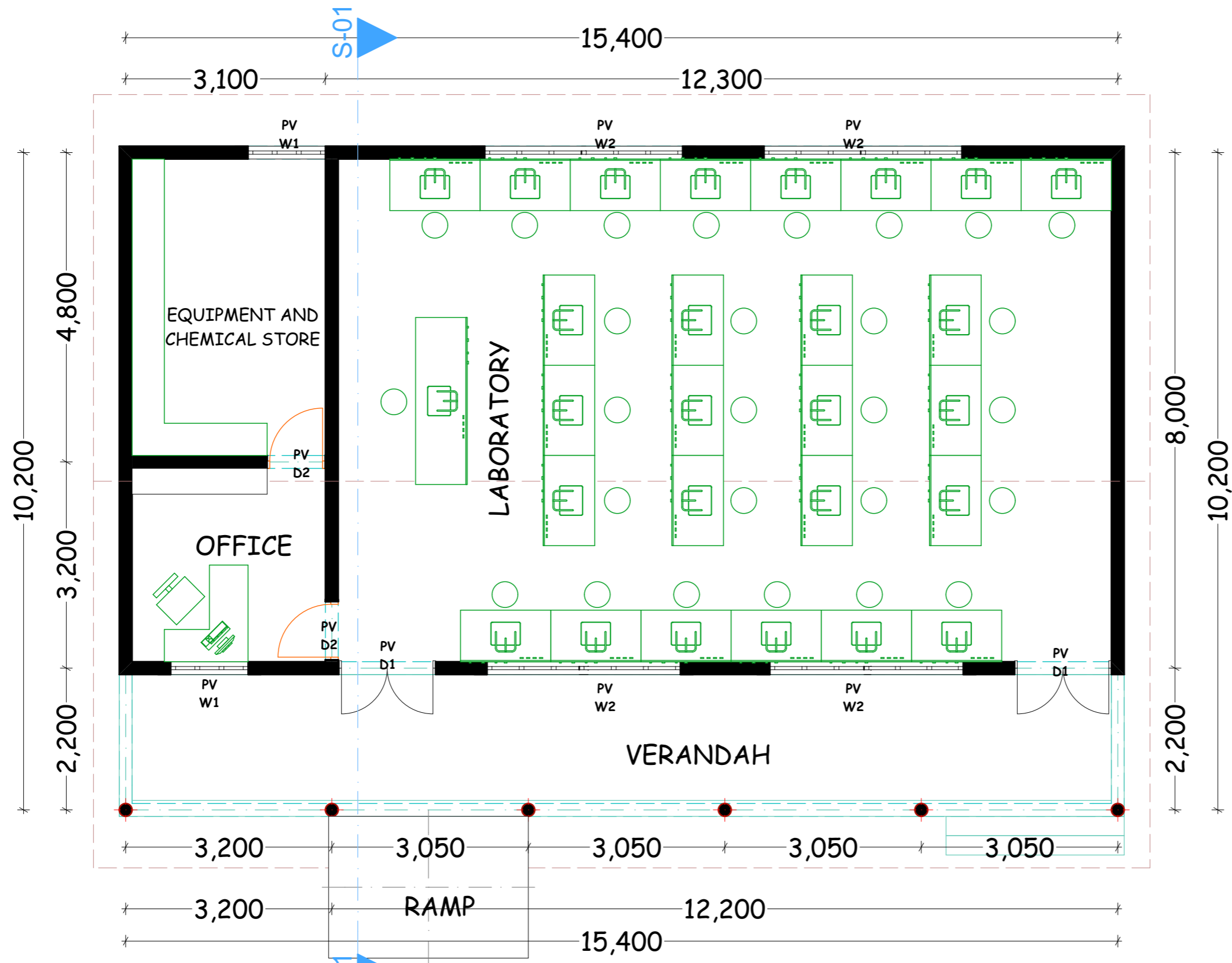

# ELEVATION 03

**GENERAL NOTES:**  
 1. All dimensions to be checked on site before commencement of any work. Use figured dimensions only. Any discrepancies should be reported to the Architect immediately.  
 2. All dimensions are in millimetres unless otherwise specified.  
 3. P.V denotes permanent vent.  
 4. Metal gutters & down pipe to suite.  
 5. All windows & doors to schedule.  
 6. All internal fittings to approval.

**CIVIL WORKS:**  
 1. All soils under slabs and around external foundations to be treated for termite control.  
 2. All soils on cut embankments to be stabilised. Slope not to exceed the natural angle of repose.  
 3. All slabs at ground level to be poured over 1000 gauge polythene sheeting on 50mm stone blinding on hardcore.

**STRUCTURAL WORKS:**  
 1. Refer to structural Engineers details for all r.c works.  
 2. Foundation depth to be determined on site to structural Engineer's approval.  
 3. All adjacent r.c work and masonry walls to be tied with strap irons at every course.

**MECHANICAL WORKS:**  
 1. All sanitary fittings, doors, windows and lifts to schedules.  
 2. All plumbing and drainage to comply with city council's specifications.  
 3. All service ducts to be accessible from every floor.

**1. FLOOR FINISHES**

**2. WALL FINISHES**

**3. CEILING FINISHES**

**4. SKIRTING FINISHES**

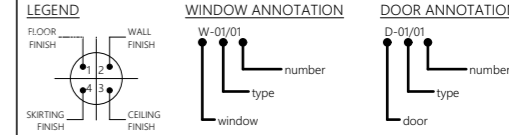

PROJECT TITLE: PROPOSED LABORATORY FOR ARINA PRIMARY SCHOOL

CLIENT: NG-CDF

LOCATION: KISUMU CENTRAL CONSTITUENCY

DRAWING SCALE: AS SHOWN

STATUS: ARCHITECTURAL DRAWINGS

**REVISIONS**

Nº	DESCRIPTION	DATE	COMMENT

**CONSULTANT**



**STATE DEPARTMENT OF PUBLIC WORKS**

JOB NUMBER: PW/1/2023

DRAWN BY: Kennedy R. Owino  
 DATE: JAN. 2023

SHEET NUMBER

# ELEVATION 04

# ELEVATION 02

# ELEVATION 01

**FLOOR LAYOUT PLAN**

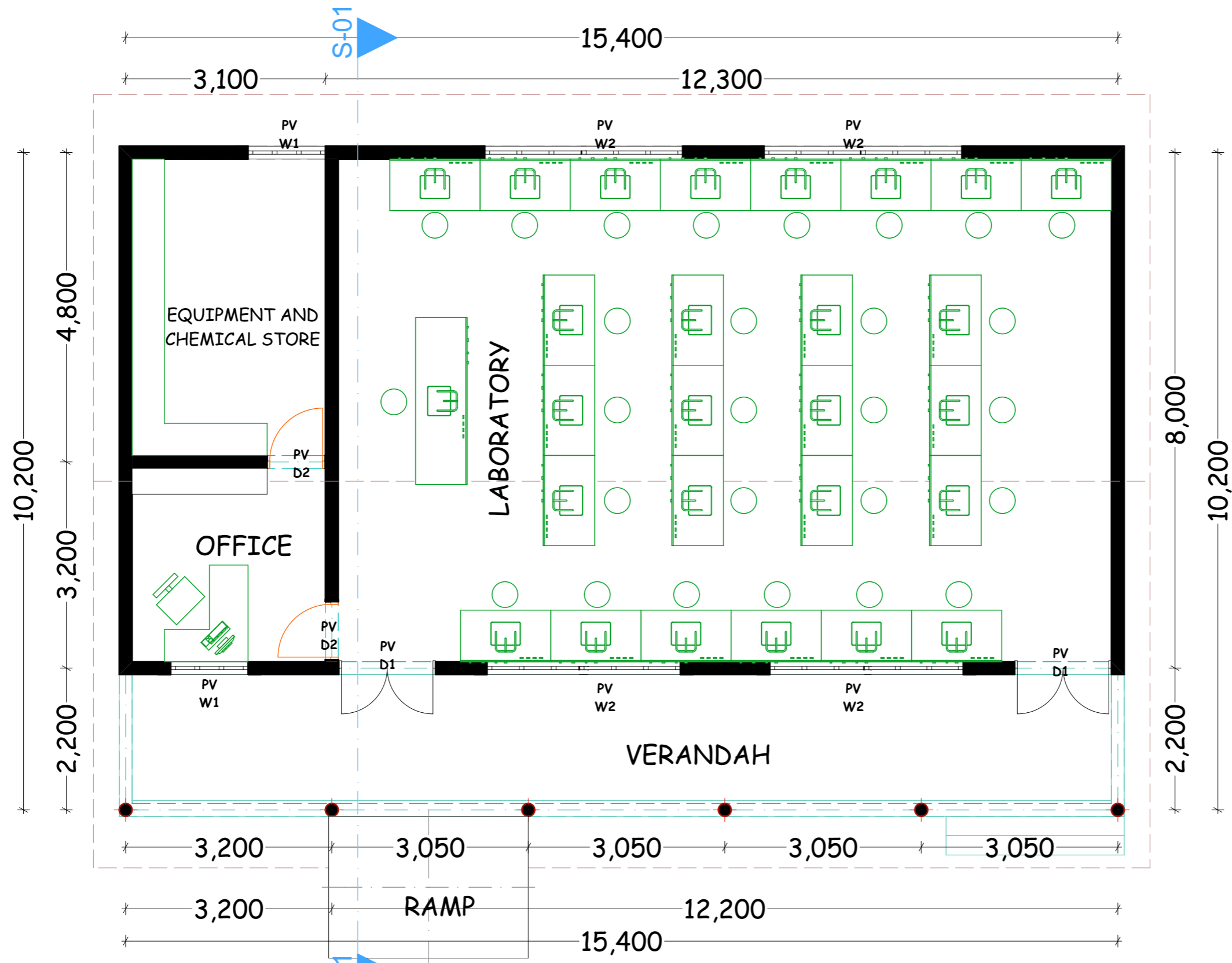

**ROOF NOTES**  
 PITCH - 30 DEG  
 Approved roofing sheet on 75x50mm  
 timber purlin on 100x50mm  
 timber trusses with 100x50mm  
 intermediate rafters all to engineer's detail  
 225x25mm verge boards 600mm wide  
 T&G eave board to deck

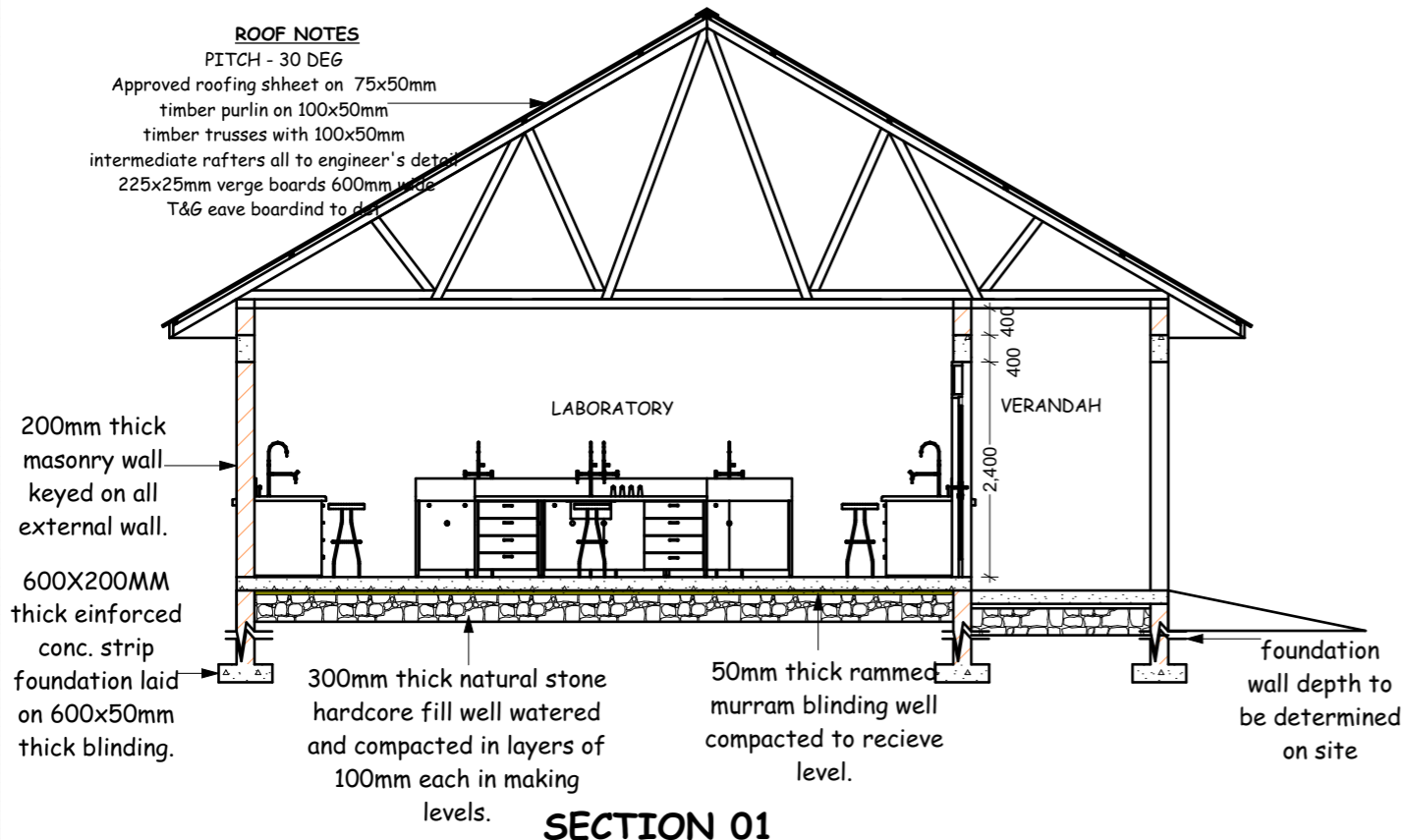

**SECTION 01**

DOOR SCHEDULE				
MATERIAL	QTY	WXH	MARK	FRONT VIEW
Mild steel Casement door	2	1,500x2,400	D1	
Semi-Solid core flush door	2	900x2,400	D2	

WINDOW SCHEDULE				
MATERIAL	QTY	WXH	MARK	FRONT VIEW
Mild steel Casement window	4	3,000x1,500	W1	
Mild steel Casement window	2	1,200x1,500	W2	

**GENERAL NOTES:**  
 1. All dimensions to be checked on site before commencement of any work. Use figured dimensions only. Any discrepancies should be reported to the Architect immediately.  
 2. All dimensions are in millimetres unless otherwise specified.  
 3. P.V denotes permanent vent.  
 4. Metal gutters & down pipe to suite.  
 5. All windows & doors to schedule.  
 6. All internal fittings to approval.

**CIVIL WORKS:**  
 1. All soils under slabs and around external foundations to be treated for termite control.  
 2. All soils on cut embankments to be stabilised. Slope not to exceed the natural angle of repose.  
 3. All slabs at ground level to be poured over 1000 gauge polythene sheeting on 50mm stone blinding on hardcore.

**STRUCTURAL WORKS:**  
 1. Refer to structural Engineers details for all r.c works.  
 2. Foundation depth to be determined on site to structural Engineer's approval.  
 3. All adjacent r.c work and masonry walls to be tied with strap irons at every course.

**MECHANICAL WORKS:**  
 1. All sanitary fittings, doors, windows and lifts to schedules.  
 2. All plumbing and drainage to comply with city council's specifications.  
 3. All service ducts to be accessible from every floor.

1. FLOOR FINISHES

2. WALL FINISHES

3. CEILING FINISHES

4. SKIRTING FINISHES

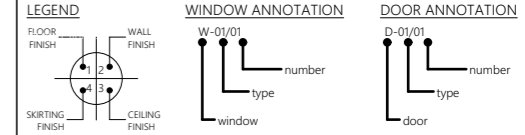

PROJECT TITLE: PROPOSED LABORATORY FOR ARINA PRIMARY SCHOOL

CLIENT: NG-CDF

LOCATION: KISUMU CENTRAL CONSTITUENCY

DRAWING SCALE: AS SHOWN

STATUS: ARCHITECTURAL DRAWINGS

REVISIONS

Nº	DESCRIPTION	DATE	COMMENT

**CONSULTANT**

**STATE DEPARTMENT OF PUBLIC WORKS**

JOB NUMBER: PW/1/2023

DRAWN BY: Kennedy R. Owino  
 DATE: JAN. 2023

SHEET NUMBER

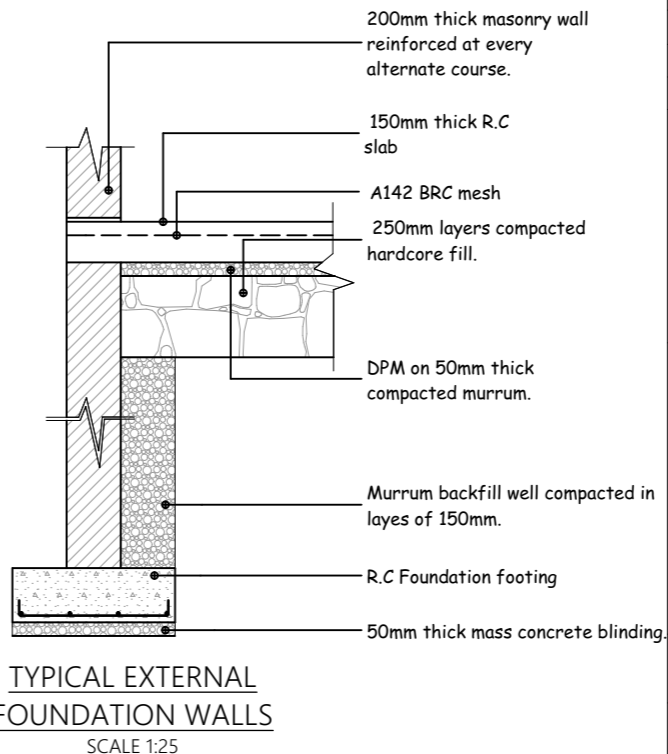
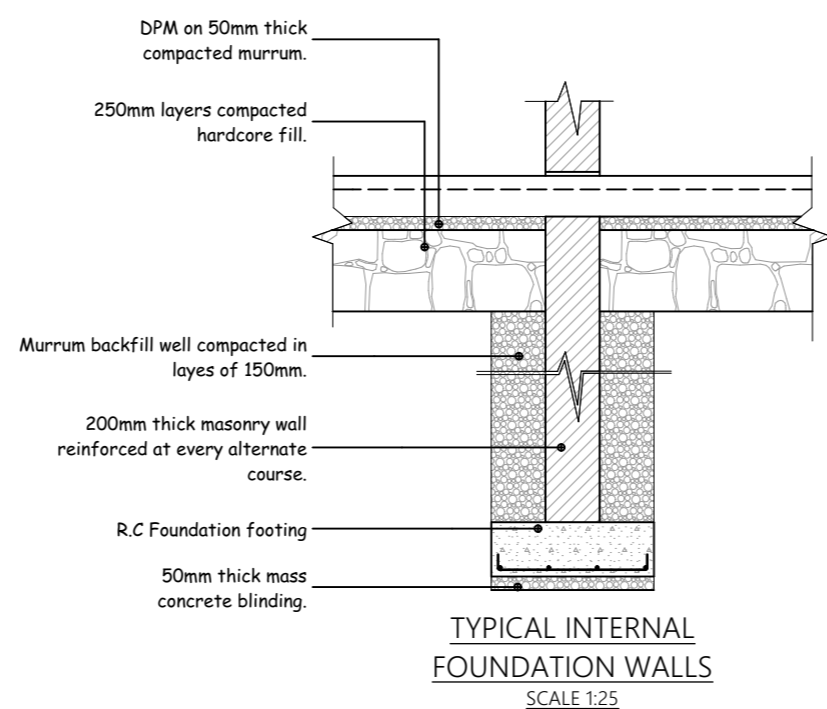
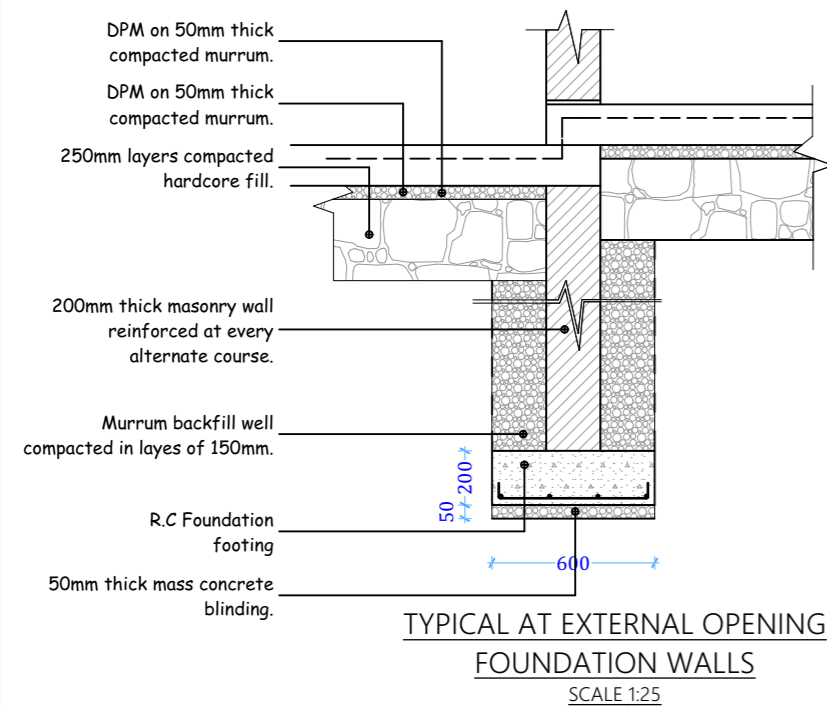

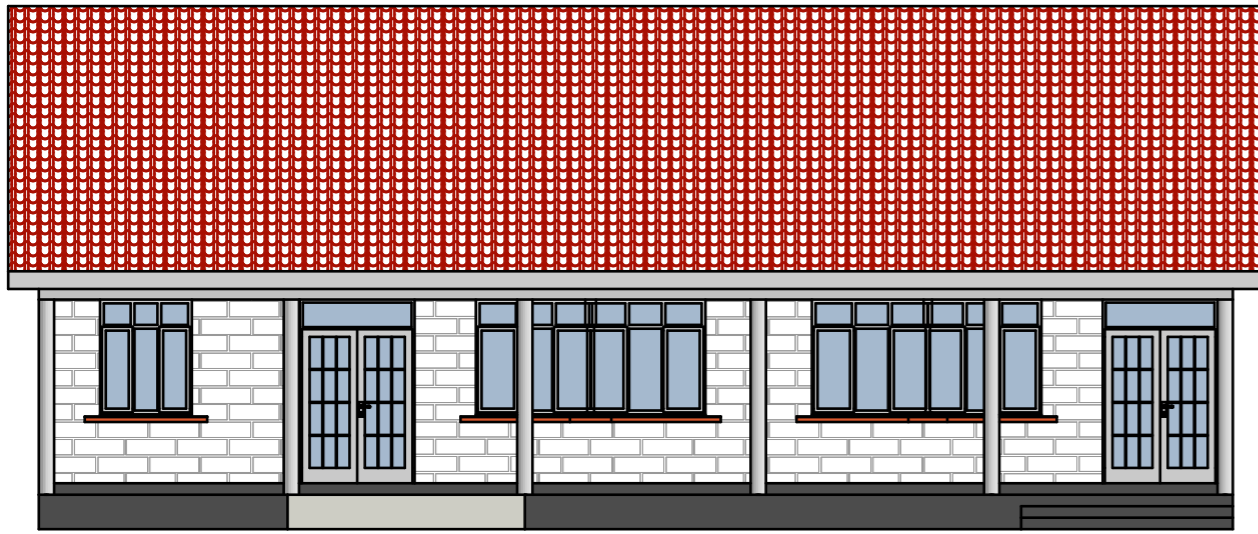

ELEVATION 01

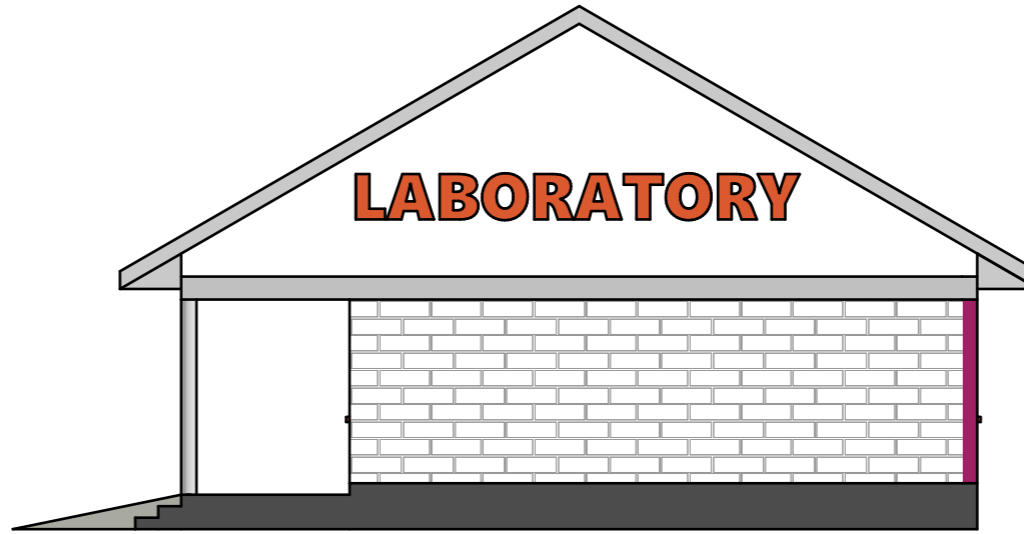

ELEVATION 02

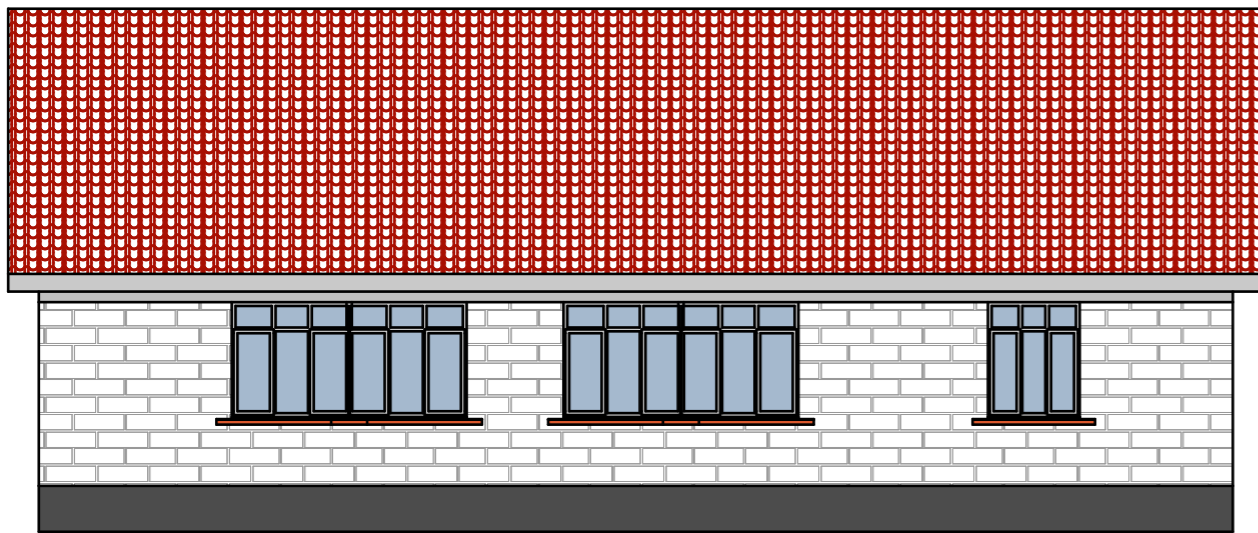

ELEVATION 03

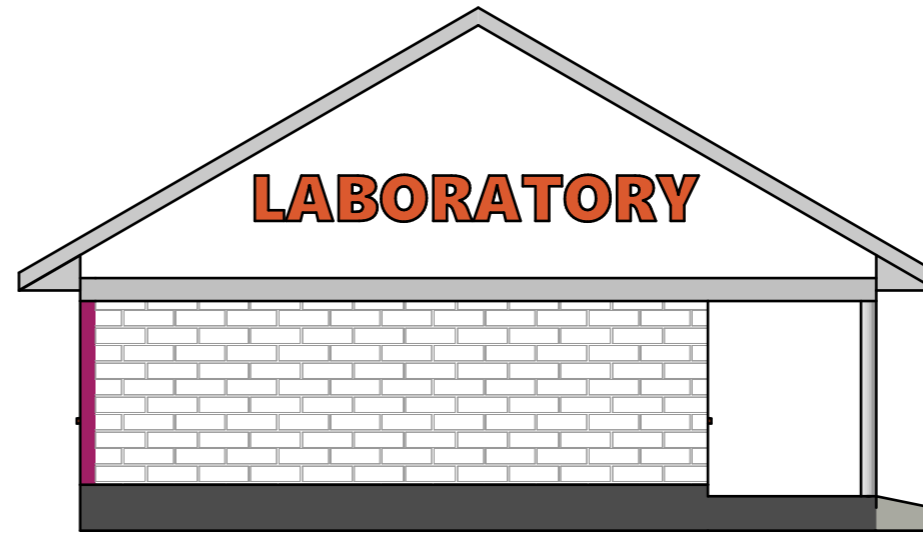

ELEVATION 04

**GENERAL NOTES:**  
 1. All dimensions to be checked on site before commencement of any work. Use figured dimensions only. Any discrepancies should be reported to the Architect immediately.  
 2. All dimensions are in millimetres unless otherwise specified.  
 3. P.V denotes permanent vent.  
 4. Metal gutters & down pipe to suite.  
 5. All windows & doors to schedule.  
 6. All internal fittings to approval.

**CIVIL WORKS:**  
 1. All soils under slabs and around external foundations to be treated for termite control.  
 2. All soils on cut embankments to be stabilised. Slope not to exceed the natural angle of repose.  
 3. All slabs at ground level to be poured over 1000 gauge polythene sheeting on 50mm stone blinding on hardcore.

**STRUCTURAL WORKS:**  
 1. Refer to structural Engineers details for all r.c works.  
 2. Foundation depth to be determined on site to structural Engineer's approval.  
 3. All adjacent r.c work and masonry walls to be tied with strap irons at every course.

**MECHANICAL WORKS:**  
 1. All sanitary fittings, doors, windows and lifts to schedules.  
 2. All plumbing and drainage to comply with city council's specifications.  
 3. All service ducts to be accessible from every floor.

**1. FLOOR FINISHES**

**2. WALL FINISHES**

**3. CEILING FINISHES**

**4. SKIRTING FINISHES**

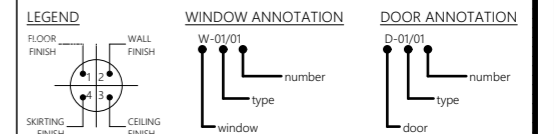

PROJECT TITLE: PROPOSED LABORATORY FOR ARINA PRIMARY SCHOOL

CLIENT: NG-CDF

LOCATION: KISUMU CENTRAL CONSTITUENCY

DRAWING SCALE: AS SHOWN

STATUS: ARCHITECTURAL DRAWINGS

REVISIONS

Nº	DESCRIPTION	DATE	COMMENT

CONSULTANT

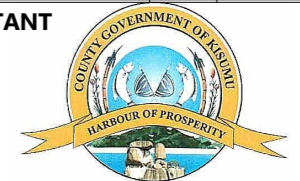

STATE DEPARTMENT OF PUBLIC WORKS

JOB NUMBER:

PW/1/2023

DRAWN BY:

Kennedy R. Owino

DATE: JAN. 2023

SHEET NUMBER

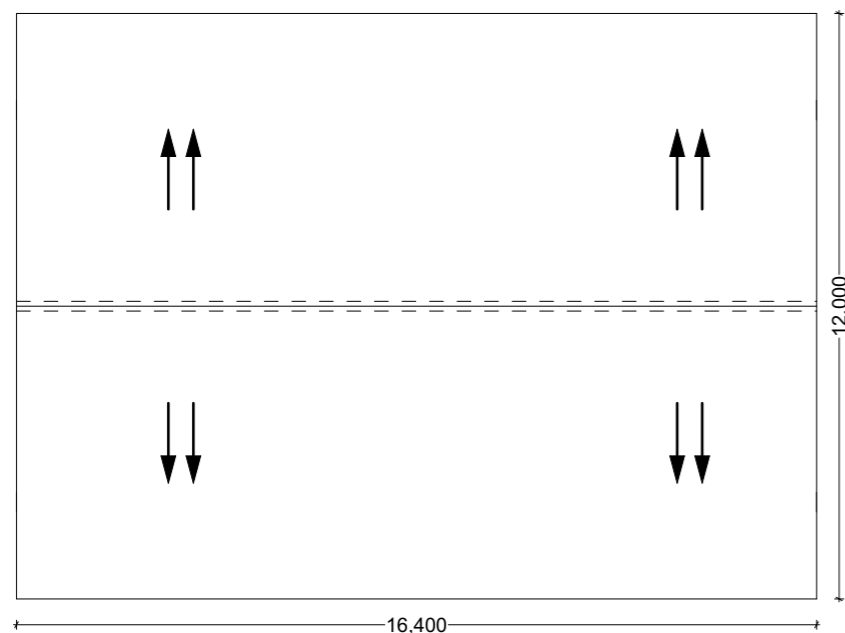

28 Gauge pre-painted corrugated iron sheet

ex 75mm X 75mm s.w moulded cornice decorated with premium grade timber Varnish.  
 12mm thick celotex ,set to symmetrical pattern 'v' joints fixed to brandering with clout headed nails

ex 50mm x 50mm wrot cypress brandering fixed to the bottom boom of the truss

100mmX50mm sawn celsured cypress rafter

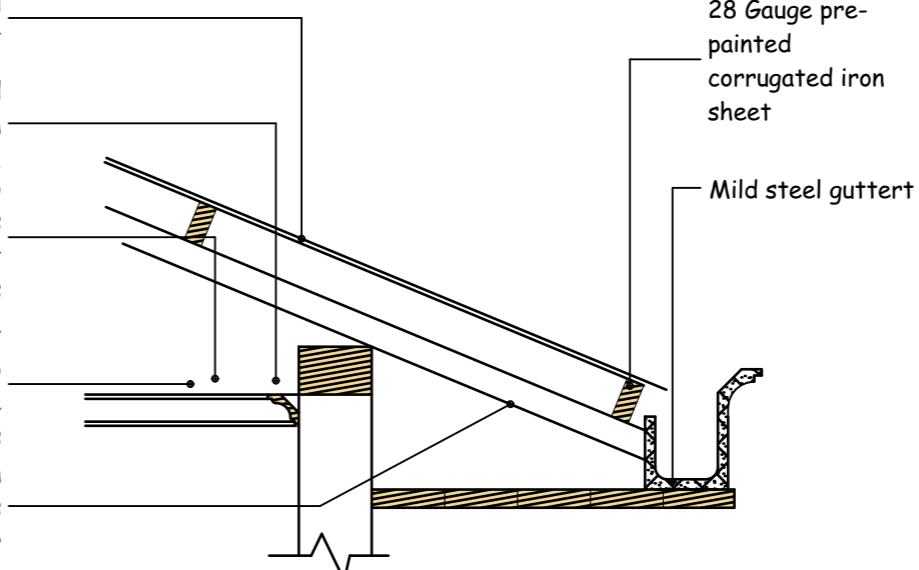

Eaves Details

**ROOF NOTES**  
 PITCH - 30 DEG  
 Approved roofing sheet on 75x50mm  
 timber purlin on 100x50mm  
 timber trusses with 100x50mm  
 intermediate rafters all to engineer's detail  
 225x25mm verge boards 600mm wide  
 T&G eave board to deck

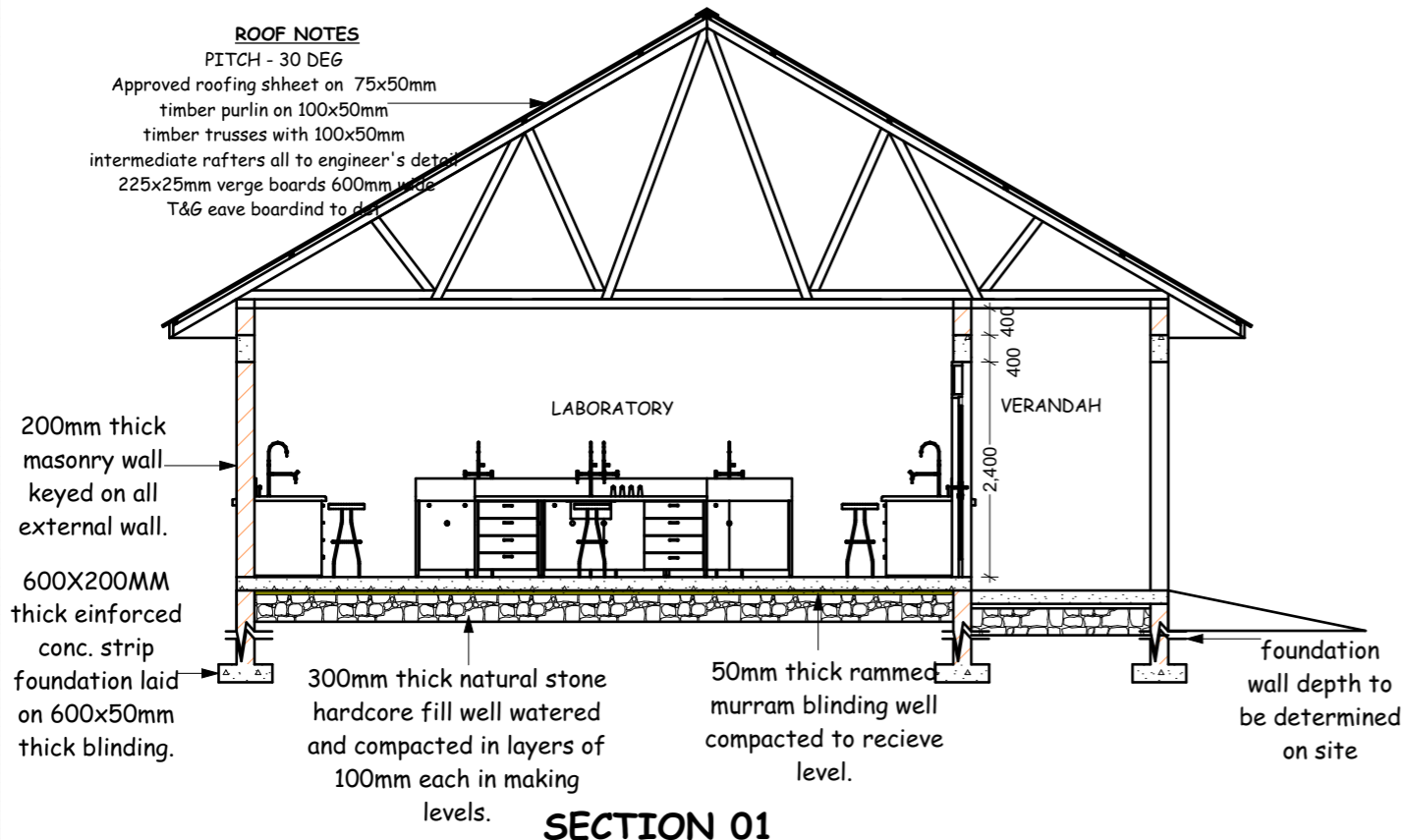

**SECTION 01**

**DOOR SCHEDULE**

MATERIAL	QTY	WXH	MARK	FRONT VIEW
Mild steel Casement door	2	1,500x2,400	D1	
Semi-Solid core flush door	2	900x2,400	D2	

**WINDOW SCHEDULE**

MATERIAL	QTY	WXH	MARK	FRONT VIEW
Mild steel Casement window	4	3,000x1,500	W1	
Mild steel Casement window	2	1,200x1,500	W2	

**GENERAL NOTES:**  
 1. All dimensions to be checked on site before commencement of any work. Use figured dimensions only. Any discrepancies should be reported to the Architect immediately.  
 2. All dimensions are in millimetres unless otherwise specified.  
 3. P.V denotes permanent vent.  
 4. Metal gutters & down pipe to suite.  
 5. All windows & doors to schedule.  
 6. All internal fittings to approval.

**CIVIL WORKS:**  
 1. All soils under slabs and around external foundations to be treated for termite control.  
 2. All soils on cut embankments to be stabilised. Slope not to exceed the natural angle of repose.  
 3. All slabs at ground level to be poured over 1000 gauge polythene sheeting on 50mm stone blinding on hardcore.

**STRUCTURAL WORKS:**  
 1. Refer to structural Engineers details for all r.c works.  
 2. Foundation depth to be determined on site to structural Engineer's approval.  
 3. All adjacent r.c work and masonry walls to be tied with strap irons at every course.

**MECHANICAL WORKS:**  
 1. All sanitary fittings, doors, windows and lifts to schedules.  
 2. All plumbing and drainage to comply with city council's specifications.  
 3. All service ducts to be accessible from every floor.

**1. FLOOR FINISHES**

**2. WALL FINISHES**

**3. CEILING FINISHES**

**4. SKIRTING FINISHES**

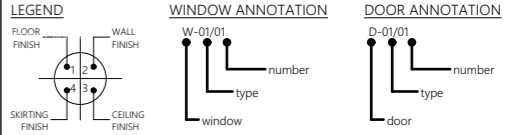

PROJECT TITLE: PROPOSED LABORATORY FOR ARINA PRIMARY SCHOOL

CLIENT: NG-CDF

LOCATION: KISUMU CENTRAL CONSTITUENCY

DRAWING SCALE: AS SHOWN

STATUS: ARCHITECTURAL DRAWINGS

**REVISIONS**

Nº	DESCRIPTION	DATE	COMMENT

**CONSULTANT**

**STATE DEPARTMENT OF PUBLIC WORKS**

JOB NUMBER: PW/1/2023

DRAWN BY: Kennedy R. Owino

DATE: JAN. 2023

SHEET NUMBER

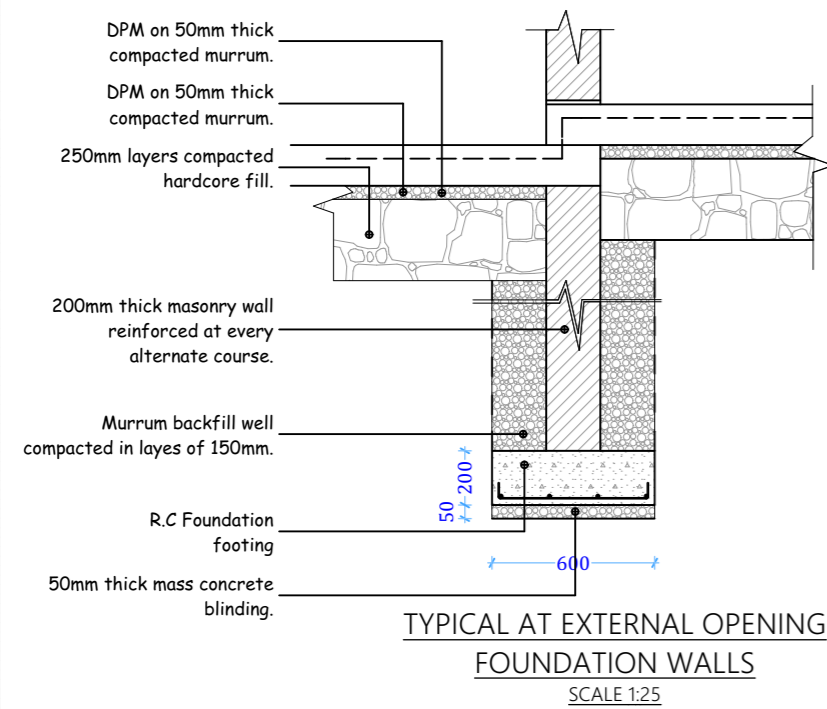

**TYPICAL AT EXTERNAL OPENING FOUNDATION WALLS**  
 SCALE 1:25

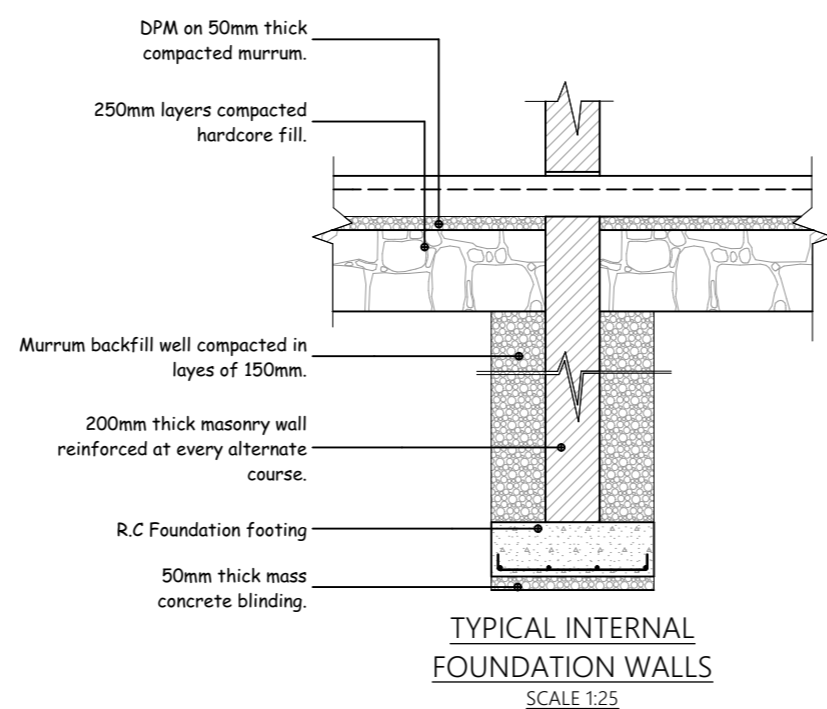

**TYPICAL INTERNAL FOUNDATION WALLS**  
 SCALE 1:25

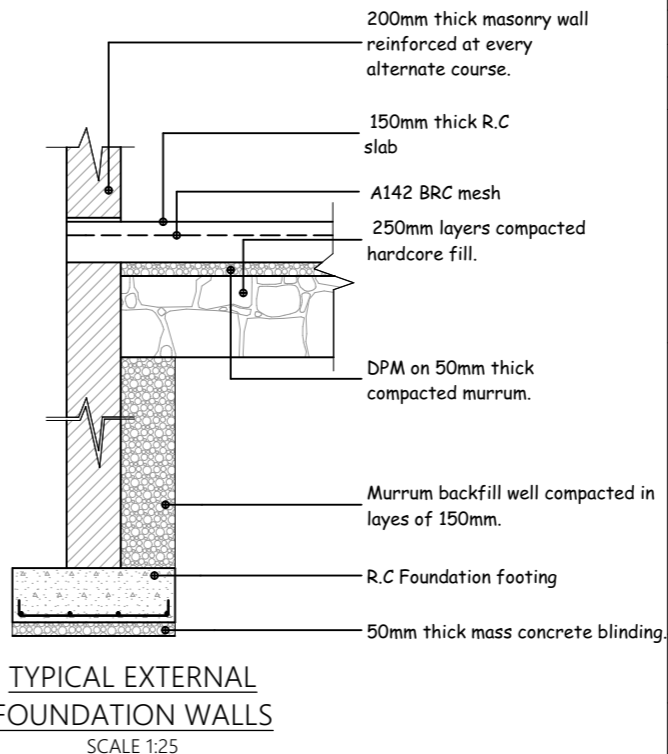

**TYPICAL EXTERNAL FOUNDATION WALLS**  
 SCALE 1:25

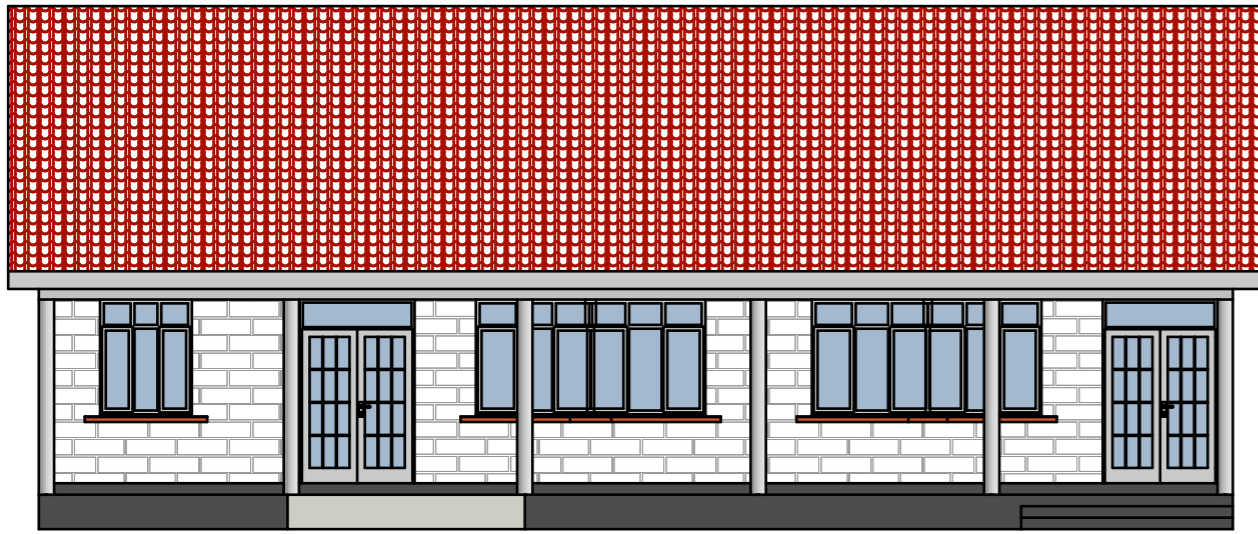

ELEVATION 01

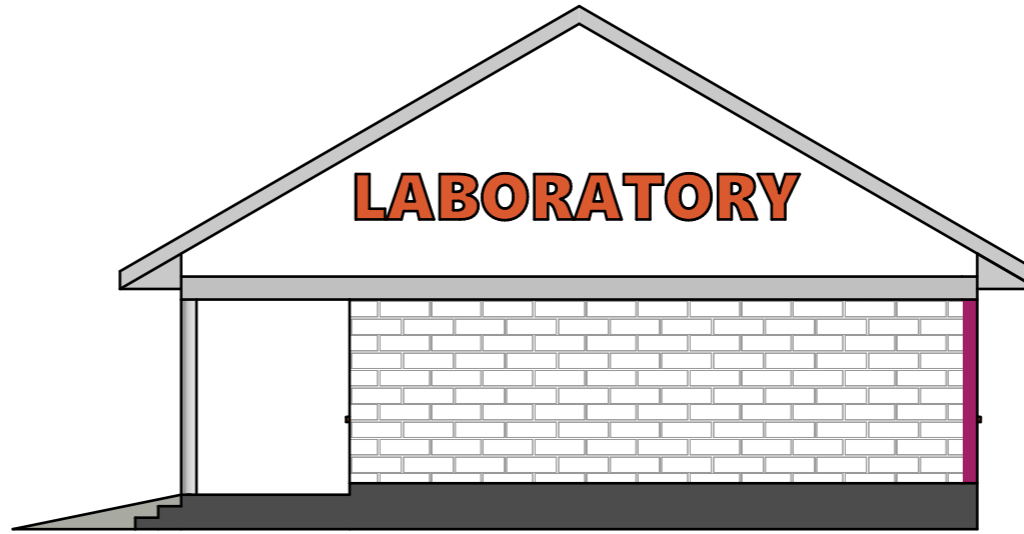

ELEVATION 02

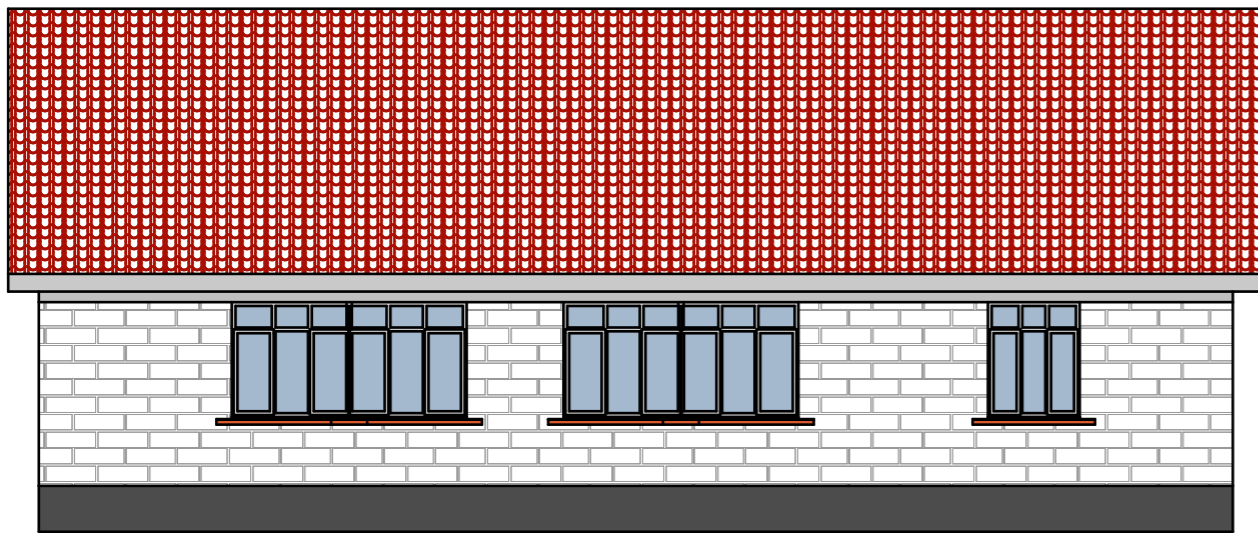

ELEVATION 03

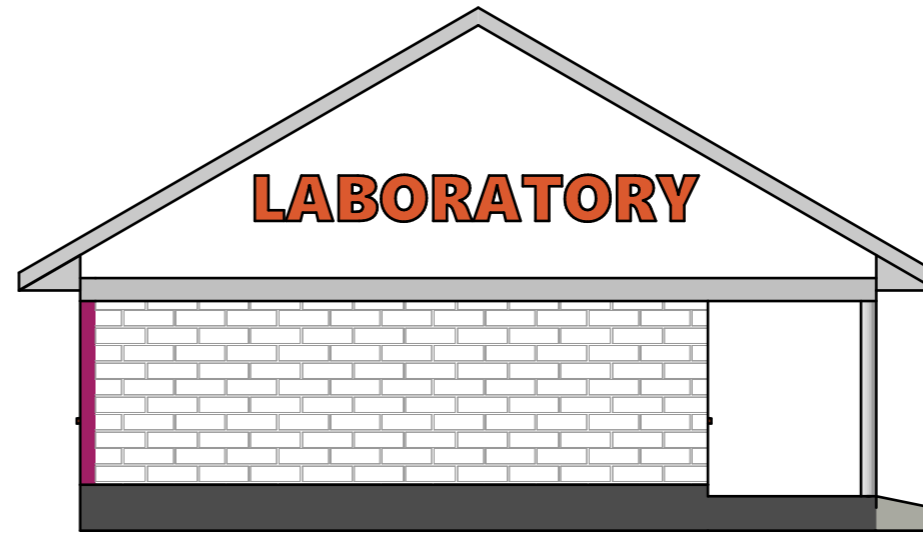

ELEVATION 04

- GENERAL NOTES:**
1. All dimensions to be checked on site before commencement of any work. Use figured dimensions only. Any discrepancies should be reported to the Architect immediately.
  2. All dimensions are in millimetres unless otherwise specified.
  3. P.V denotes permanent vent.
  4. Metal gutters & down pipe to suite.
  5. All windows & doors to schedule.
  6. All internal fittings to approval.

- CIVIL WORKS:**
1. All soils under slabs and around external foundations to be treated for termite control.
  2. All soils on cut embankments to be stabilised. Slope not to exceed the natural angle of repose.
  3. All slabs at ground level to be poured over 1000 gauge polythene sheeting on 50mm stone blinding on hardcore.

- STRUCTURAL WORKS:**
1. Refer to structural Engineers details for all r.c works.
  2. Foundation depth to be determined on site to structural Engineer's approval.
  3. All adjacent r.c work and masonry walls to be tied with strap irons at every course.

- MECHANICAL WORKS:**
1. All sanitary fittings, doors, windows and lifts to schedules.
  2. All plumbing and drainage to comply with city council's specifications.
  3. All service ducts to be accessible from every floor.

**1. FLOOR FINISHES**

**2. WALL FINISHES**

**3. CEILING FINISHES**

**4. SKIRTING FINISHES**

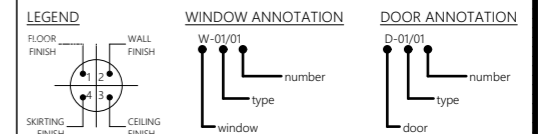

PROJECT TITLE: PROPOSED LABORATORY FOR ARINA PRIMARY SCHOOL

CLIENT: NG-CDF

LOCATION: KISUMU CENTRAL CONSTITUENCY

DRAWING SCALE: AS SHOWN

STATUS: ARCHITECTURAL DRAWINGS

**REVISIONS**

Nº	DESCRIPTION	DATE	COMMENT

**CONSULTANT**

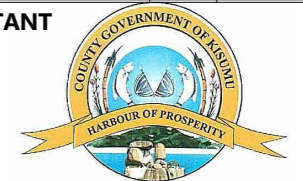

**STATE DEPARTMENT OF PUBLIC WORKS**

JOB NUMBER:

PW/1/2023

DRAWN BY:  
Kennedy R. Owino  
DATE: JAN. 2023

SHEET NUMBER

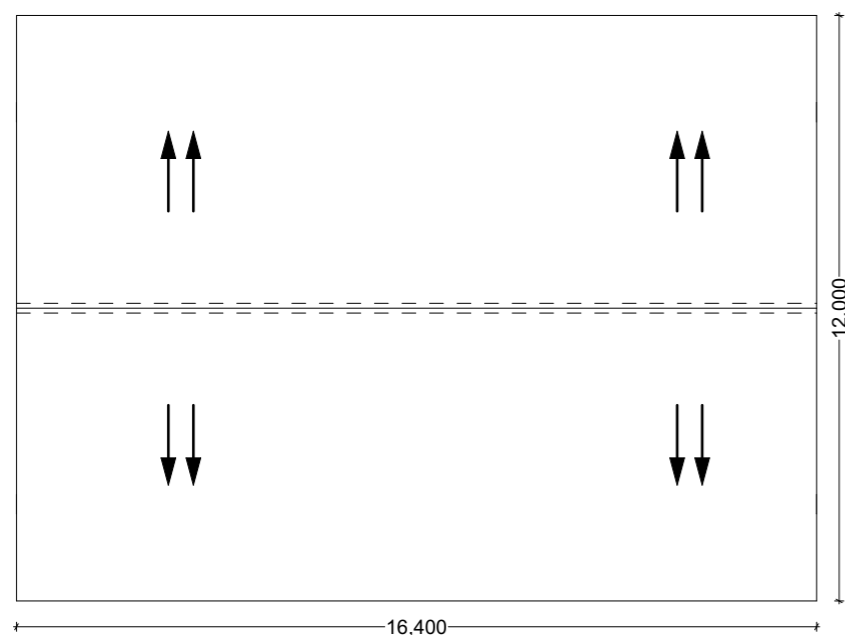

- 28 Gauge pre-painted corrugated iron sheet
- ex 75mm X 75mm s.w moulded cornice decorated with premium grade timber Varnish.
- 12mm thick celotex ,set to symmetrical pattern 'v' joints fixed to brandering with clout headed nails
- ex 50mm x 50mm wrot cypress brandering fixed to the bottom boom of the truss
- 100mmX50mm sawn celsured cypress rafter

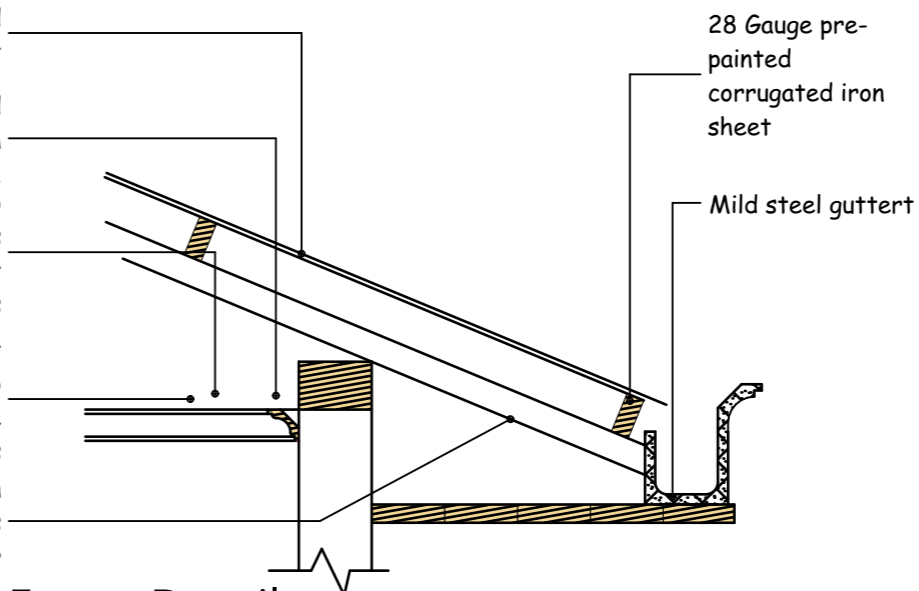

Eaves Details



---

**PART III - CONDITIONS OF CONTRACT AND  
CONTRACT FORMS**

---

## SECTION VIII - GENERAL CONDITIONS OF CONTRACT

These General Conditions of Contract (GCC), read in conjunction with the Special Conditions of Contract (SCC) and other documents listed therein, should be a complete document expressing fairly the rights and obligations of both parties.

These General Conditions of Contract have been developed on the basis of considerable international experience in the drafting and management of contracts, bearing in mind a trend in the construction industry towards simpler, more straightforward language.

The GCC can be used for both smaller admeasurement contracts and lump sum contracts.

General Conditions of Contract

### A. General

#### 1. Definitions

Boldface type is used to identify defined terms.

- a) **The Accepted Contract Amount** means the amount accepted in the Letter of Acceptance for the execution and completion of the Works and the remedying of any defects.
- b) **The Activity Schedule** is a schedule of the activities comprising the construction, installation, testing, and commissioning of the Works in a lump sum contract. It includes a lump sum price for each activity, which is used for valuations and for assessing the effects of Variations and Compensation Events.
- c) **The Adjudicator** is the person appointed jointly by the Procuring Entity and the Contractor to resolve disputes in the first instance, as provided for in GCC 23.
- d) **Bill of Quantities** means the priced and completed Bill of Quantities forming part of the Bid.
- e) **Compensation Events** are those defined in GCC Clause 42 hereunder.
- f) **The Completion Date** is the date of completion of the Works as certified by the Project Manager, in accordance with GCC Sub-Clause 53.1.
- g) **The Contract** is the Contract between the Procuring Entity and the Contractor to execute, complete, and maintain the Works. It consists of the documents listed in GCC Sub-Clause 2.3 below.
- h) **The Contractor** is the party whose Bid to carry out the Works has been accepted by the Procuring Entity.
- i) **The Contractor's Bid** is the completed bidding document submitted by the Contractor to the Procuring Entity.
- j) **The Contract Price** is the Accepted Contract Amount stated in the Letter of Acceptance and thereafter as adjusted in accordance with the Contract.
- k) **Days** are calendar days; months are calendar months.
- l) **Day works** are varied work inputs subject to payment on a time basis for the Contractor's employees and Equipment, in addition to payments for associated Materials and Plant.
- m) **ADefect** is any part of the Works not completed in accordance with the Contract.
- n) **The Defects Liability Certificate** is the certificate issued by Project Manager upon correction of defects by the Contractor.
- o) **The Defects Liability Period** is the period **named in the SCC** pursuant to Sub-Clause 34.1 and calculated from the Completion Date.
- p) **Drawings** means the drawings of the Works, as included in the Contract, and any additional and modified drawings issued by (or on behalf of) the Procuring Entity in accordance with the Contract, include calculations and other information provided or approved by the Project Manager for the execution of the Contract.
- q) **The Procuring Entity** is the party who employs the Contractor to carry out the Works, **as specified in the SCC**, who is also the Procuring Entity.
- r) **Equipment** is the Contractor's machinery and vehicles brought temporarily to the Site to construct the Works.
- s) **"In writing" or "written"** means hand-written, type-written, printed or electronically made, and resulting in a permanent record;

- t) The Initial Contract Price is the Contract Price listed in the Procuring Entity's Letter of Acceptance.
- u) **The Intended Completion Date** is the date on which it is intended that the Contractor shall complete the Works. The Intended Completion Date is **specified in the SCC**. The Intended Completion Date may be revised only by the Project Manager by issuing an extension of time or an acceleration order.
- v) **Materials** are all supplies, including consumables, used by the Contractor for incorporation in the Works.
- w) **Plant** is any integral part of the Works that shall have a mechanical, electrical, chemical, or biological function.
- x) **The Project Manager** is the person **named in the SCC** (or any other competent person appointed by the Procuring Entity and notified to the Contractor, to act in replacement of the Project Manager) who is responsible for supervising the execution of the Works and administering the Contract.
- y) **SCC** means Special Conditions of Contract.
- z) **The Site** is the area of the works as **defined as such in the SCC**.
  - aa) **Site Investigation Reports** are those that were included in the bidding document and are factual and interpretative reports about the surface and subsurface conditions at the Site.
  - bb) **Specification** means the Specification of the Works included in the Contract and any modification or addition made or approved by the Project Manager.
  - cc) **The Start Date** is **given in the SCC**. It is the latest date when the Contractor shall commence execution of the Works. It does not necessarily coincide with any of the Site Possession Dates.
  - dd) **A Subcontractor** is a person or corporate body who has a Contract with the Contractor to carry out a part of the work in the Contract, which includes work on the Site.
  - ee) **Temporary Works** are works designed, constructed, installed, and removed by the Contractor that are needed for construction or installation of the Works.
  - ff) **A Variation** is an instruction given by the Project Manager which varies the Works.
  - gg) **The Works** are what the Contract requires the Contractor to construct, install, and turn over to the Procuring Entity, **as defined in the SCC**.

## 2 Interpretation

In interpreting these GCC, words indicating one gender include all genders. Words indicating the singular also include the plural and words indicating the plural also include the singular. Headings have no significance. Words have their normal meaning under the language of the Contract unless specifically defined. The Project Manager shall provide instructions clarifying queries about these GCC.

If sectional completion is **specified in the SCC**, references in the GCC to the Works, the Completion Date, and the Intended Completion Date apply to any Section of the Works (other than references to the Completion Date and Intended Completion Date for the whole of the Works).

The documents forming the Contract shall be interpreted in the following order of priority:

- a) Agreement,
- b) Letter of Acceptance,
- c) Contractor's Bid,
- d) Special Conditions of Contract,
- e) General Conditions of Contract, including Appendices,
- f) Specifications,
- g) Drawings,
- h) Bill of Quantities<sup>6</sup>, and
- i) any other document **listed in the SCC** as forming part of the Contract.

## 3 Language and Law

The language of the Contract is English Language and the law governing the Contract are the Laws of Kenya.

Throughout the execution of the Contract, the Contractor shall comply with the import of goods and services prohibitions in the Procuring Entity's Country when

- a) as a matter of law or official regulations, Kenya prohibits commercial relations with that country; or
- b) by an act of compliance with a decision of the United Nations Security Council taken under Chapter VII of the Charter of the United Nations, Kenya prohibits any import of goods from that country or any payments to any

country, person, or entity in that country.

#### 4. Project Manager's Decisions

Except where otherwise specifically stated, the Project Manager shall decide contractual matters between the Procuring Entity and the Contractor in the role representing the Procuring Entity.

#### 5. Delegation

Otherwise **specified in the SCC**, the Project Manager may delegate any of his duties and responsibilities to other people, except to the Adjudicator, after notifying the Contractor, and may revoke any delegation after notifying the Contractor.

#### 6. Communications

Communications between parties that are referred to in the Conditions shall be effective only when in writing. A notice shall be effective only when it is delivered.

#### 7. Subcontracting

The Contractor may subcontract with the approval of the Project Manager, but may not assign the Contract without the approval of the Procuring Entity in writing. Subcontracting shall not alter the Contractor's obligations.

#### 8. Other Contractors

The Contractor shall cooperate and share the Site with other contractors, public authorities, utilities, and the Procuring Entity between the dates given in the Schedule of Other Contractors, as **referred to in the SCC**. The Contractor shall also provide facilities and services for them as described in the Schedule. The Procuring Entity may modify the Schedule of Other Contractors, and shall notify the Contractor of any such modification.

#### 9. Personnel and Equipment

The Contractor shall employ the key personnel and use the equipment identified in its Bid, to carry out the Works or other personnel and equipment approved by the Project Manager. The Project Manager shall approve any proposed replacement of key personnel and equipment only if their relevant qualifications or characteristics are substantially equal to or better than those proposed in the Bid.

If the Project Manager asks the Contractor to remove a person who is a member of the Contractor's staff or work force, stating the reasons, the Contractor shall ensure that the person leaves the Site within seven days and has no further connection with the work in the Contract.

If the Procuring Entity, Project Manager or Contractor determines, that any employee of the Contractor be determined to have engaged in Fraud and Corruption during the execution of the Works, then that employee shall be removed in accordance with Clause 9.2 above.

#### 10. Procuring Entity's and Contractor's Risks

The Procuring Entity carries the risks which this Contract states are Procuring Entity's risks, and the Contractor carries the risks which this Contract states are Contractor's risks.

#### 11. Procuring Entity's Risks

From the Start Date until the Defects Liability Certificate has been issued, the following are Procuring Entity's risks:

- a) The risk of personal injury, death, or loss of or damage to property (excluding the Works, Plant, Materials,

and Equipment), which are due to

- i) use or occupation of the Site by the Works or for the purpose of the Works, which is the unavoidable result of the Works or
  - ii) negligence, breach of statutory duty, or interference with any legal right by the Procuring Entity or by any person employed by or contracted to him except the Contractor.
- b) The risk of damage to the Works, Plant, Materials, and Equipment to the extent that it is due to a fault of the Procuring Entity or in the Procuring Entity's design, or due to war or radioactive contamination directly affecting the country where the Works are to be executed.

From the Completion Date until the Defects Liability Certificate has been issued, the risk of loss of or damage to the Works, Plant, and Materials is a Procuring Entity's risk except loss or damage due to

- a) a Defect which existed on the Completion Date,
- b) an event occurring before the Completion Date, which was not itself a Procuring Entity's risk, or
- c) the activities of the Contractor on the Site after the Completion Date.

## 12. Contractor's Risks

From the Starting Date until the Defects Liability Certificate has been issued, the risks of personal injury, death, and loss of or damage to property (including, without limitation, the Works, Plant, Materials, and Equipment) which are not Procuring Entity's risks are Contractor's risks.

## 13. Insurance

The Contractor shall provide, in the joint names of the Procuring Entity and the Contractor, insurance cover from the Start Date to the end of the Defects Liability Period, in the amounts and deductibles **stated in the SCC** for the following events which are due to the Contractor's risks:

- a) loss of or damage to the Works, Plant, and Materials;
- b) loss of or damage to Equipment;
- c) loss of or damage to property (except the Works, Plant, Materials, and Equipment) in connection with the Contract; and
- d) personal injury or death.

Policies and certificates for insurance shall be delivered by the Contractor to the Project Manager for the Project Manager's approval before the Start Date. All such insurance shall provide for compensation to be payable in the types and proportions of currencies required to rectify the loss or damage incurred.

If the Contractor does not provide any of the policies and certificates required, the Procuring Entity may affect the insurance which the Contractor should have provided and recover the premiums the Procuring Entity has paid from payments otherwise due to the Contractor or, if no payment is due, the payment of the premiums shall be a debt due.

Alterations to the terms of an insurance shall not be made without the approval of the Project Manager.

Both parties shall comply with any conditions of the insurance policies.

## 14. Site Data

The Contractor shall be deemed to have examined any Site Data **referred to in the SCC**, supplemented by any information available to the Contractor.

## 15. Contractor to Construct the Works

The Contractor shall construct and install the Works in accordance with the Specifications and Drawings.

## 16. The Works to Be Completed by the Intended Completion Date

The Contractor may commence execution of the Works on the Start Date and shall carry out the Works in accordance with the Program submitted by the Contractor, as updated with the approval of the Project Manager, and complete them by the Intended Completion Date.

**17. Approval by the Project Manager**

The Contractor shall submit Specifications and Drawings showing the proposed Temporary Works to the Project Manager, for his approval.

The Contractor shall be responsible for design of Temporary Works.

The Project Manager's approval shall not alter the Contractor's responsibility for design of the Temporary Works. The Contractor shall obtain approval of third parties to the design of the Temporary Works, where required.

All Drawings prepared by the Contractor for the execution of the temporary or permanent Works, are subject to prior approval by the Project Manager before this use.

**18. Safety**

The Contractor shall be responsible for the safety of all activities on the Site.

**19. Discoveries**

Anything of historical or other interest or of significant value unexpectedly discovered on the Site shall be the property of the Procuring Entity. The Contractor shall notify the Project Manager of such discoveries and carry out the Project Manager's instructions for dealing with them.

**20. Possession of the Site**

The Procuring Entity shall give possession of all parts of the Site to the Contractor. If possession of a part is not given by the date **stated in the SCC**, the Procuring Entity shall be deemed to have delayed the start of the relevant activities, and this shall be a Compensation Event.

**21. Access to the Site**

The Contractor shall allow the Project Manager and any person authorized by the Project Manager access to the Site and to any place where work in connection with the Contract is being carried out or is intended to be carried out.

**22. Instructions, Inspections and Audits**

The Contractor shall carry out all instructions of the Project Manager which comply with the applicable laws where the Site is located.

The Contractor shall keep, and shall make all reasonable efforts to cause its Subcontractors and sub-consultants to keep, accurate and systematic accounts and records in respect of the Works in such form and details as will clearly identify relevant time changes and costs.

The Contractor shall permit and shall cause its subcontractors and sub-consultants to permit, the Procuring Entity and/or persons appointed by the Public Procurement Regulatory Authority to inspect the Site and/or the accounts and records relating to the procurement process, selection and/or contract execution, and to have such accounts and records audited by auditors appointed by the Public Procurement Regulatory Authority. The Contractor's and its Subcontractors' and sub-consultants' attention is drawn to Sub-Clause 25.1 (Fraud and Corruption) which provides, inter alia, that acts intended to materially impede the exercise of the Public Procurement Regulatory Authority's inspection and audit rights constitute a prohibited practice subject to contract termination (as well as to a determination of ineligibility pursuant to the Public Procurement Regulatory Authority's prevailing sanctions procedures).

### 23. Appointment of the Adjudicator

The Adjudicator shall be appointed jointly by the Procuring Entity and the Contractor, at the time of the Procuring Entity's issuance of the Letter of Acceptance. If, in the Letter of Acceptance, the Procuring Entity does not agree on the appointment of the Adjudicator, the Procuring Entity will request the Appointing Authority **designated in the SCC**, to appoint the Adjudicator within 14 days of receipt of such request.

Should the Adjudicator resign or die, or should the Procuring Entity and the Contractor agree that the Adjudicator is not functioning in accordance with the provisions of the Contract, a new Adjudicator shall be jointly appointed by the Procuring Entity and the Contractor. In case of disagreement between the Procuring Entity and the Contractor, within 30 days, the Adjudicator shall be designated by the Appointing Authority **designated in the SCC** at the request of either party, within 14 days of receipt of such request.

### 24. Settlement of Claims and Disputes

#### Contractor's Claims

If the Contractor considers itself to be entitled to any extension of the Time for Completion and/or any additional payment, under any Clause of these Conditions or otherwise in connection with the Contract, the Contractor shall give Notice to the Project Manager, describing the event or circumstance giving rise to the claim. The notice shall be given as soon as practicable, and not later than 30 days after the Contractor became aware, or should have become aware, of the event or circumstance.

If the Contractor fails to give notice of a claim within such period of 30 days, the Time for Completion shall not be extended,

the Contractor shall not be entitled to additional payment, and the Procuring Entity shall be discharged from all liability in connection with the claim. Otherwise, the following provisions of this Sub- Clause shall apply.

The Contractor shall also submit any other notices which are required by the Contract, and supporting particulars for the claim, all as relevant to such event or circumstance.

The Contractor shall keep such contemporary records as may be necessary to substantiate any claim, either on the Site or at another location acceptable to the Project Manager. Without admitting the Procuring Entity's liability, the Project Manager may, after receiving any notice under this Sub-Clause, monitor the record-keeping and/or instruct the Contractor to keep further contemporary records. The Contractor shall permit the Project Manager to inspect all these records, and shall (if instructed) submit copies to the Project Manager.

Within 42 days after the Contractor became aware (or should have become aware) of the event or circumstance giving rise to the claim, or within such other period as may be proposed by the Contractor and approved by the Project Manager, the Contractor shall send to the Project Manager a fully detailed claim which includes full supporting particulars of the basis of the claim and of the extension of time and/or additional payment claimed. If the event or circumstance giving rise to the claim has a continuing effect:

- a) this fully detailed claim shall be considered as interim;
- b) the Contractor shall send further interim claims at monthly intervals, giving the accumulated delay and/or amount claimed, and such further particulars as the Project Manager may reasonably require; and
- c) the Contractor shall send a final claim within 30 days after the end of the effects resulting from the event or circumstance, or within such other period as may be proposed by the Contractor and approved by the Project Manager.

Within 42 days after receiving a Notice of a claim or any further particulars supporting a previous claim, or within such other period as may be proposed by the Project Manager and approved by the Contractor, the Project Manager shall respond with approval, or with disapproval and detailed comments. He may also request any necessary further particulars, but shall nevertheless give his response on the principles of the claim within the above defined time period.

Within the above defined period of 42 days, the Project Manager shall proceed in accordance with Sub-Clause

3.5 [Determinations] to agree or determine (i) the extension (if any) of the Time for Completion (before or after its expiry) in accordance with Sub-Clause 8.4 [Extension of Time for Completion], and/or (ii) the additional payment (if any) to which the Contractor is entitled under the Contract.

Each Payment Certificate shall include such additional payment for any claim as has been reasonably substantiated as due under the relevant provision of the Contract. Unless and until the particulars supplied are sufficient to substantiate the whole of the claim, the Contractor shall only be entitled to payment for such part of the claim as he has been able to substantiate.

If the Project Manager does not respond within the timeframe defined in this Clause, either Party may consider that the claim is rejected by the Project Manager and any of the Parties may refer to Arbitration in accordance with Sub-Clause 24.4 [Arbitration].

The requirements of this Sub-Clause are in addition to those of any other Sub-Clause which may apply to a claim. If the Contractor fails to comply with this or another Sub-Clause in relation to any claim, any extension of time and/or additional payment shall take account of the extent (if any) to which the failure has prevented or prejudiced proper investigation of the claim, unless the claim is excluded under the second paragraph of this Sub-Clause 24.3.

#### Amicable Settlement

Where a notice of a claim has been given, both Parties shall attempt to settle the dispute amicably before the commencement of arbitration. However, unless both Parties agree otherwise, the Party giving a notice of a claim in accordance with Sub-Clause 24.1 above should move to commence arbitration after the fifty-sixth day from the day on which a notice of a claim was given, even if no attempt at an amicable settlement has been made.

#### Matters that may be referred to arbitration

Notwithstanding anything stated herein the following matters may be referred to arbitration before the practical completion of the Works or abandonment of the Works or termination of the Contract by either party:

- a) The appointment of a replacement Project Manager upon the said person ceasing to act.
- b) Whether or not the issue of an instruction by the Project Manager is empowered by these Conditions.
- c) Whether or not a certificate has been improperly withheld or is not in accordance with these Conditions.
- e) Any dispute arising in respect of war risks or war damage.
- f) All other matters shall only be referred to arbitration after the completion or alleged completion of the Works or termination or alleged termination of the Contract, unless the Procuring Entity and the Contractor agree otherwise in writing.

#### Arbitration

Any claim or dispute between the Parties arising out of or in connection with the Contract not settled amicably in accordance with Sub-Clause 24.3 shall be finally settled by arbitration.

No arbitration proceedings shall be commenced on any claim or dispute where notice of a claim or dispute has not been given by the applying party within ninety days of the occurrence or discovery of the matter or issue giving rise to the dispute.

Notwithstanding the issue of a notice as stated above, the arbitration of such a claim or dispute shall not commence unless an attempt has in the first instance been made by the parties to settle such claim or dispute amicably with or without the assistance of third parties. Proof of such attempt shall be required.

The Arbitrator shall, without prejudice to the generality of his powers, have powers to direct such measurements, computations, tests or valuations as may in his opinion be desirable in order to determine the rights of the parties and assess and award any sums which ought to have been the subject of or included in any certificate.

The Arbitrator shall, without prejudice to the generality of his powers, have powers to open up, review and revise any certificate, opinion, decision, requirement or notice and to determine all matters in dispute which shall be

submitted to him in the same manner as if no such certificate, opinion, decision requirement or notice had been given.

The arbitrators shall have full power to open up, review and revise any certificate, determination, instruction, opinion or valuation of the Project Manager, relevant to the dispute. Nothing shall disqualify representatives of the Parties and the Project Manager from being called as a witness and giving evidence before the arbitrators on any matter whatsoever relevant to the dispute.

Neither Party shall be limited in the proceedings before the arbitrators to the evidence, or to the reasons for dissatisfaction given in its Notice of Dissatisfaction.

Arbitration may be commenced prior to or after completion of the Works. The obligations of the Parties, and the Project Manager shall not be altered by reason of any arbitration being conducted during the progress of the Works.

24.4.8 The terms of the remuneration of each or all the members of Arbitration shall be mutually agreed upon by the Parties when agreeing the terms of appointment. Each Party shall be responsible for paying one-half of this remuneration.

#### Arbitration with National Contractors

If the Contract is with national contractors, arbitration proceedings will be conducted in accordance with the Arbitration Laws of Kenya. In case of any claim or dispute, such claim or dispute shall be notified in writing by either party to the other with a request to submit it to arbitration and to concur in the appointment of an Arbitrator within thirty days of the notice. The dispute shall be referred to the arbitration and final decision of a person to be agreed between the parties. Failing agreement to concur in the appointment of an Arbitrator, the Arbitrator shall be appointed, on the request of the applying party, by the Chairman or Vice Chairman of any of the following professional institutions;

- i) Architectural Association of Kenya
- ii) Institute of Quantity Surveyors of Kenya
- iii) Association of Consulting Engineers of Kenya
- iv) Chartered Institute of Arbitrators (Kenya Branch)
- v) Institution of Engineers of Kenya

The institution written to first by the aggrieved party shall take precedence over all other institutions.

#### Alternative Arbitration Proceedings

Alternatively, the Parties may refer the matter to the Nairobi Centre for International Arbitration (NCIA) which offers a neutral venue for the conduct of national and international arbitration with commitment to providing institutional support to the arbitral process.

#### Failure to Comply with Arbitrator's Decision

The award of such Arbitrator shall be final and binding upon the parties.

In the event that a Party fails to comply with a final and binding Arbitrator's decision, then the other Party may, without prejudice to any other rights it may have, refer the matter to a competent court of law.

#### Contract operations to continue

Notwithstanding any reference to arbitration herein,

- a) the parties shall continue to perform their respective obligations under the Contract unless they otherwise agree; and
- b) the Procuring Entity shall pay the Contractor any monies due the Contractor.

## 25. Fraud and Corruption

The Government requires compliance with the country's Anti-Corruption laws and its prevailing sanctions policies and procedures as set forth in the Constitution of Kenya and its Statutes.

The Procuring Entity requires the Contractor to disclose any commissions or fees that may have been paid or are to be paid to agents or any other party with respect to the bidding process or execution of the Contract. The information disclosed must include at least the name and address of the agent or other party, the amount and currency, and the purpose of the commission, gratuity or fee.

### B. Time Control

#### 1. Program

Within the time **stated in the SCC**, after the date of the Letter of Acceptance, the Contractor shall submit to the Project Manager for approval a Program showing the general methods, arrangements, order, and timing for all the activities in the Works. In the case of a lump sum contract, the activities in the Program shall be consistent with those in the Activity Schedule.

An update of the Program shall be a program showing the actual progress achieved on each activity and the effect of the progress achieved on the timing of the remaining work, including any changes to the sequence of the activities.

The Contractor shall submit to the Project Manager for approval an updated Program at intervals no longer than the period **stated in the SCC**. If the Contractor does not submit an updated Program within this period, the Project Manager may withhold the amount **stated in the SCC** from the next payment certificate and continue to withhold this amount until the next payment after the date on which the overdue Program has been submitted. In the case of a lump sum contract, the Contractor shall provide an updated Activity Schedule within 14 days of being instructed to by the Project Manager.

The Project Manager's approval of the Program shall not alter the Contractor's obligations. The Contractor may revise the Program and submit it to the Project Manager again at any time. A revised Program shall show the effect of Variations and Compensation Events.

#### 2. Extension of the Intended Completion Date

The Project Manager shall extend the Intended Completion Date if a Compensation Event occurs or a Variation is issued which makes it impossible for Completion to be achieved by the Intended Completion Date without the Contractor taking steps to accelerate the remaining work, which would cause the Contractor to incur additional cost.

The Project Manager shall decide whether and by how much to extend the Intended Completion Date within 21 days of the Contractor asking the Project Manager for a decision upon the effect of a Compensation Event or Variation and submitting full supporting information. If the Contractor has failed to give early warning of a delay or has failed to cooperate in dealing with a delay, the delay by this failure shall not be considered in assessing the new Intended Completion Date.

#### 3. Acceleration

When the Procuring Entity wants the Contractor to finish before the Intended Completion Date, the Project Manager shall obtain priced proposals for achieving the necessary acceleration from the Contractor. If the Procuring Entity accepts these proposals, the Intended Completion Date shall be adjusted accordingly and confirmed by both the Procuring Entity and the Contractor.

If the Contractor's priced proposals for an acceleration are accepted by the Procuring Entity, they are incorporated in the Contract Price and treated as a Variation.

#### 4. Delays Ordered by the Project Manager

The Project Manager may instruct the Contractor to delay the start or progress of any activity within the Works.

#### 5. Management Meetings

Either the Project Manager or the Contractor may require the other to attend a management meeting. The business of a management meeting shall be to review the plans for remaining work and to deal with matters raised in accordance with the early warning procedure.

The Project Manager shall record the business of management meetings and provide copies of the record to those attending the meeting and to the Procuring Entity. The responsibility of the parties for actions to be taken shall be decided by the Project Manager either at the management meeting or after the management meeting and stated in writing to all who attended the meeting.

#### 6. Early Warning

The Contractor shall warn the Project Manager at the earliest opportunity of specific likely future events or circumstances that may adversely affect the quality of the work, increase the Contract Price, or delay the execution of the Works. The Project Manager may require the Contractor to provide an estimate of the expected effect of the future event or circumstance on the Contract Price and Completion Date. The estimate shall be provided by the Contractor as soon as reasonably possible.

The Contractor shall cooperate with the Project Manager in making and considering proposals for how the effect of such an event or circumstance can be avoided or reduced by anyone involved in the work and in carrying out any resulting instruction of the Project Manager.

### C. Quality Control

#### 1. Identifying Defects

The Project Manager shall check the Contractor's work and notify the Contractor of any Defects that are found. Such checking shall not affect the Contractor's responsibilities. The Project Manager may instruct the Contractor to search for a Defect and to uncover and test any work that the Project Manager considers may have a Defect.

#### 2. Tests

If the Project Manager instructs the Contractor to carry out a test not specified in the Specification to check whether any work has a Defect and the test shows that it does, the Contractor shall pay for the test and any samples. If there is no Defect, the test shall be a Compensation Event.

#### 3. Correction of Defects

The Project Manager shall give notice to the Contractor of any Defects before the end of the Defects Liability Period, which begins at Completion, and is **defined in the SCC**. The Defects Liability Period shall be extended for as long as Defects remain to be corrected.

Every time notice of a Defect is given, the Contractor shall correct the notified Defect within the length of time specified by the Project Manager's notice.

#### 4. Uncorrected Defects

If the Contractor has not corrected a Defect within the time specified in the Project Manager's notice, the Project Manager shall assess the cost of having the Defect corrected, and the Contractor shall pay this amount.

## D. Cost Control

### 1. Contract Price<sup>7</sup>

The Bill of Quantities shall contain priced items for the Works to be performed by the Contractor. The Bill of Quantities is used to calculate the Contract Price. The Contractor will be paid for the quantity of the work accomplished at the rate in the Bill of Quantities for each item.

### 2. Changes in the Contract Price<sup>8</sup>

If the final quantity of the work done differs from the quantity in the Bill of Quantities for the particular item by more than 25 percent, provided the change exceeds 1 percent of the Initial Contract Price, the Project Manager shall adjust the rate to allow for the change. The Project Manager shall not adjust rates from changes in quantities if thereby the Initial Contract Price is exceeded by more than 15 percent, except with the prior approval of the Procuring Entity.

If requested by the Project Manager, the Contractor shall provide the Project Manager with a detailed cost breakdown of any rate in the Bill of Quantities.

### 3. Variations

All Variations shall be included in updated Programs<sup>9</sup> produced by the Contractor.

The Contractor shall provide the Project Manager with a quotation for carrying out the Variation when requested to do so by the Project Manager. The Project Manager shall assess the quotation, which shall be given within seven (7) days of the request or within any longer period stated by the Project Manager and before the Variation is ordered.

If the Contractor's quotation is unreasonable, the Project Manager may order the Variation and make a change to the Contract Price, which shall be based on the Project Manager's own forecast of the effects of the Variation on the Contractor's costs.

If the Project Manager decides that the urgency of varying the work would prevent a quotation being given and considered without delaying the work, no quotation shall be given and the Variation shall be treated as a Compensation Event.

The Contractor shall not be entitled to additional payment for costs that could have been avoided by giving early warning.

If the work in the Variation corresponds to an item description in the Bill of Quantities and if, in the opinion of the Project Manager, the quantity of work above the limit stated in Sub-Clause 39.1 or the timing of its execution do not cause the cost per unit of quantity to change, the rate in the Bill of Quantities shall be used to calculate the value of the Variation. If the cost per unit of quantity changes, or if the nature or timing of the work in the Variation does not correspond with items in the Bill of Quantities, the quotation by the Contractor shall be in the form of new rates for the relevant items of work<sup>10</sup>.

Value Engineering: The Contractor may prepare, at its own cost, a value engineering proposal at any time during the performance of the contract. The value engineering proposal shall, at a minimum, include the following;

- a) the proposed change(s), and a description of the difference to the existing contract requirements;
- b) a full cost/benefit analysis of the proposed change(s) including a description and estimate of costs (including life cycle costs) the Procuring Entity may incur in implementing the value engineering proposal; and
- c) a description of any effect(s) of the change on performance/functionality.

The Procuring Entity may accept the value engineering proposal if the proposal demonstrates benefits that: accelerate the contract completion period; or reduce the Contract Price or the life cycle costs to the Procuring Entity; or improve the quality, efficiency, safety or sustainability of the Facilities; or yield any other benefits to the Procuring Entity, without compromising the functionality of the Works.

If the value engineering proposal is approved by the Procuring Entity and results in:

- a) a reduction of the Contract Price; the amount to be paid to the Contractor shall be the **percentage specified in**

the SCC of the reduction in the Contract Price; or

b) an increase in the Contract Price; but results in a reduction in life cycle costs due to any benefit described in

(a) to (d) above, the amount to be paid to the Contractor shall be the full increase in the Contract Price.

#### 4. Cash Flow Forecasts

When the Program<sup>11</sup>, is updated, the Contractor shall provide the Project Manager with an updated cash flow forecast. The cash flow forecast shall include different currencies, as defined in the Contract, converted as necessary using the Contract exchange rates.

#### 5. Payment Certificates

The Contractor shall submit to the Project Manager monthly statements of the estimated value of the work executed less the cumulative amount certified previously.

The Project Manager shall check the Contractor's monthly statement and certify the amount to be paid to the Contractor. The value of work executed shall be determined by the Project Manager.

The value of work executed shall comprise the value of the quantities of work in the Bill of Quantities that have been completed<sup>12</sup>.

The value of work executed shall include the valuation of Variations and Compensation Events.

The Project Manager may exclude any item certified in a previous certificate or reduce the proportion of any item previously certified in any certificate in the light of later information.

Where the contract price is different from the corrected tender price, in order to ensure the contractor is not paid less or more relative to the contract price (*which would be the tender price*), payment valuation certificates and variation orders on omissions and additions valued based on rates in the Bill of Quantities or schedule of rates in the Tender, will be adjusted by a plus or minus percentage. The percentage already worked out during tender evaluation is worked out as follows:  $(\text{corrected tender price} - \text{tender price}) / \text{tender price} \times 100$ .

#### 6. Payments

Payments shall be adjusted for deductions for advance payments and retention. The Procuring Entity shall pay the Contractor the amounts certified by the Project Manager within 30 days of the date of each certificate. If the Procuring Entity makes a late payment, the Contractor shall be paid interest on the late payment in the next payment. Interest shall be calculated from the date by which the payment should have been made up to the date when the late payment is made at the prevailing rate of interest for commercial borrowing for each of the currencies in which payments are made.

If an amount certified is increased in a later certificate or as a result of an award by the Adjudicator or an Arbitrator, the Contractor shall be paid interest upon the delayed payment as set out in this clause. Interest shall be calculated from the date upon which the increased amount would have been certified in the absence of dispute.

Unless otherwise stated, all payments and deductions shall be paid or charged in the proportions of currencies comprising the Contract Price.

Items of the Works for which no rate or price has been entered in shall not be paid for by the Procuring Entity and shall be deemed covered by other rates and prices in the Contract.

## 7. Compensation Events

The following shall be Compensation Events:

- a) The Procuring Entity does not give access to a part of the Site by the Site Possession Date pursuant to GCC Sub-Clause 20.1.
- b) The Procuring Entity modifies the Schedule of Other Contractors in a way that affects the work of the Contractor under the Contract.
- c) The Project Manager orders a delay or does not issue Drawings, Specifications, or instructions required for execution of the Works on time.
- d) The Project Manager instructs the Contractor to uncover or to carry out additional tests upon work, which is then found to have no Defects.
- e) The Project Manager unreasonably does not approve a subcontract to be let.
- f) Ground conditions are substantially more adverse than could reasonably have been assumed before issuance of the Letter of Acceptance from the information issued to bidders (including the Site Investigation Reports), from information available publicly and from a visual inspection of the Site.
- a) The Project Manager gives an instruction for dealing with an unforeseen condition, caused by the Procuring Entity, or additional work required for safety or other reasons.
- b) Other contractors, public authorities, utilities, or the Procuring Entity does not work within the dates and other constraints stated in the Contract, and they cause delay or extra cost to the Contractor.
- c) The advance payment is delayed.
- d) The effects on the Contractor of any of the Procuring Entity's Risks.
- e) The Project Manager unreasonably delays issuing a Certificate of Completion.

If a Compensation Event would cause additional cost or would prevent the work being completed before the Intended Completion Date, the Contract Price shall be increased and/or the Intended Completion Date shall be extended. The Project Manager shall decide whether and by how much the Contract Price shall be increased and whether and by how much the Intended Completion Date shall be extended.

As soon as information demonstrating the effect of each Compensation Event upon the Contractor's forecast cost has been provided by the Contractor, it shall be assessed by the Project Manager, and the Contract Price shall be adjusted accordingly. If the Contractor's forecast is deemed unreasonable, the Project Manager shall adjust the Contract Price based on the Project Manager's own forecast. The Project Manager shall assume that the Contractor shall react competently and promptly to the event.

The Contractor shall not be entitled to compensation to the extent that the Procuring Entity's interests are adversely affected by the Contractor's not having given early warning or not having cooperated with the Project Manager.

## 9. Retention

The Procuring Entity shall retain from each payment due to the Contractor the proportion **stated in the SCC** until Completion of the whole of the Works.

Upon the issue of a Certificate of Completion of the Works by the Project Manager, in accordance with GCC 53.1, half the total amount retained shall be repaid to the Contractor and half when the Defects Liability Period has passed and the Project Manager has certified that all Defects notified by the Project Manager to the Contractor before the end of this period have been corrected. The Contractor may substitute retention money with an “on demand” Bank guarantee.

## Liquidated Damages

The Contractor shall pay liquidated damages to the Procuring Entity at the rate per day stated in the SCC for each day that the Completion Date is later than the Intended Completion Date. The total amount of liquidated damages shall not exceed the amount defined in the SCC. The Procuring Entity may deduct liquidated damages from payments due to the Contractor. Payment of liquidated damages shall not affect the Contractor's liabilities.

If the Intended Completion Date is extended after liquidated damages have been paid, the Project Manager shall correct any overpayment of liquidated damages by the Contractor by adjusting the next payment certificate. The Contractor shall be paid interest on the overpayment, calculated from the date of payment to the date of repayment, at the rates specified in GCC Sub-Clause 41.1

### 1. Bonus

The Contractor shall be paid a Bonus calculated at the rate per calendar day **stated in the SCC** for each day (less any days for which the Contractor is paid for acceleration) that the Completion is earlier than the Intended Completion Date. The Project Manager shall certify that the Works are complete, although they may not be due to be complete.

### 2. Advance Payment

The Procuring Entity shall make advance payment to the Contractor of the amounts **stated in the SCC** by the date **stated in the SCC**, against provision by the Contractor of an Unconditional Bank Guarantee in a form and by a bank acceptable to the Procuring Entity in amounts and currencies equal to the advance payment. The Guarantee shall remain effective until the advance payment has been repaid, but the amount of the Guarantee shall be progressively reduced by the amounts repaid by the Contractor. Interest shall not be charged on the advance payment.

The Contractor is to use the advance payment only to pay for Equipment, Plant, Materials, and mobilization expenses required specifically for execution of the Contract. The Contractor shall demonstrate that advance payment has been used in this way by supplying copies of invoices or other documents to the Project Manager.

The advance payment shall be repaid by deducting proportionate amounts from payments otherwise due to the Contractor, following the schedule of completed percentages of the Works on a payment basis. No account shall be taken of the advance payment or its repayment in assessing valuations of work done, Variations, price adjustments<sup>c</sup>, Com<sup>c</sup> pensation Events, Bonuses, or Liquidated Damages.

### 3. Securities

The Performance Security shall be provided to the Procuring Entity no later than the date specified in the Letter of Acceptance and shall be issued in an amount **specified in the SCC**, by a bank or surety acceptable to the Procuring Entity, and denominated in the types and proportions of the currencies in which the Contract Price is payable. The Performance Security shall be valid until a date 28 day from the date of issue of the Certificate of Completion in the case of a Bank Guarantee, and until one year from the date of issue of the Completion Certificate in the case of a Performance Bond.

### 4. Dayworks

If applicable, the Dayworks rates in the Contractor's Bid shall be used only when the Project Manager has given written instructions in advance for additional work to be paid for in that way.

All work to be paid for as Dayworks shall be recorded by the Contractor on forms approved by the Project Manager. Each completed form shall be verified and signed by the Project Manager within two days of the work being done.

The Contractor shall be paid for Dayworks subject to obtaining signed Dayworks forms.

### 5. Cost of Repairs

Loss or damage to the Works or Materials to be incorporated in the Works between the Start Date and the end of the Defects Correction periods shall be remedied by the Contractor at the Contractor's cost if the loss or damage arises from the Contractor's acts or omissions.

## E. Finishing the Contract

### 1. Completion

The Contractor shall request the Project Manager to issue a Certificate of Completion of the Works, and the Project Manager shall do so upon deciding that the whole of the Works is completed.

### 2. Taking Over

The Procuring Entity shall take over the Site and the Works within seven days of the Project Manager's issuing a certificate of Completion.

### 3. Final Account

The Contractor shall supply the Project Manager with a detailed account of the total amount that the Contractor considers payable under the Contract before the end of the Defects Liability Period. The Project Manager shall issue a Defects Liability Certificate and certify any final payment that is due to the Contractor within 56 days of receiving the Contractor's account if it is correct and complete. If it is not, the Project Manager shall issue within 56 days a schedule that states the scope of the corrections or additions that are necessary. If the Final Account is still unsatisfactory after it has been resubmitted, the Project Manager shall decide on the amount payable to the Contractor and issue a payment certificate.

### 4. Operating and Maintenance Manuals

If "as built" Drawings and/or operating and maintenance manuals are required, the Contractor shall supply them by the dates **stated in the SCC**.

If the Contractor does not supply the Drawings and/or manuals by the dates **stated in the SCC** pursuant to GCC Sub-Clause 56.1, or they do not receive the Project Manager's approval, the Project Manager shall withhold the amount **stated in the SCC** from payments due to the Contractor.

## 5. Termination

The Procuring Entity or the Contractor may terminate the Contract if the other party causes a fundamental breach of the Contract.

Fundamental breaches of Contract shall include, but shall not be limited to, the following:

- a) the Contractor stops work for 30 days when no stoppage of work is shown on the current Program and the stoppage has not been authorized by the Project Manager;
- b) the Project Manager instructs the Contractor to delay the progress of the Works, and the instruction is not withdrawn within 30 days;
- c) the Procuring Entity or the Contractor is made bankrupt or goes into liquidation other than for a reconstruction or amalgamation;
- d) a payment certified by the Project Manager is not paid by the Procuring Entity to the Contractor within 84 days of the date of the Project Manager's certificate;
- e) the Project Manager gives Notice that failure to correct a particular Defect is a fundamental breach of Contract and the Contractor fails to correct it within a reasonable period of time determined by the Project Manager;
- f) the Contractor does not maintain a Security, which is required;
- g) the Contractor has delayed the completion of the Works by the number of days for which the maximum amount of liquidated damages can be paid, as **defined in the SCC**; or
- h) if the Contractor, in the judgment of the Procuring Entity has engaged in Fraud and Corruption, as defined in paragraph 2.2 a of the Appendix A to the GCC, in competing for or in executing the Contract, then the Procuring Entity may, after giving fourteen (14) days written notice to the Contractor, terminate the Contract and expel him from the Site.

Notwithstanding the above, the Procuring Entity may terminate the Contract for convenience.

If the Contract is terminated, the Contractor shall stop work immediately, make the Site safe and secure, and leave the Site as soon as reasonably possible.

When either party to the Contract gives notice of a breach of Contract to the Project Manager for a cause other than those listed under GCC Sub-Clause 56.2 above, the Project Manager shall decide whether the breach is fundamental or not

## **6 Payment upon Termination**

If the Contract is terminated because of a fundamental breach of Contract by the Contractor, the Project Manager shall issue a certificate for the value of the work done and Materials ordered less advance payments received up to the date of the issue of the certificate and less the percentage to apply to the value of the work not completed, as **specified in the SCC**. Additional Liquidated Damages shall not apply. If the total amount due to the Procuring Entity exceeds any payment due to the Contractor, the difference shall be a debt payable to the Procuring Entity.

If the Contract is terminated for the Procuring Entity's convenience or because of a fundamental breach of Contract by the Procuring Entity, the Project Manager shall issue a certificate for the value of the work done, Materials ordered, the reasonable cost of removal of Equipment, repatriation of the Contractor's personnel employed solely on the Works, and the Contractor's costs of protecting and securing the Works, and less advance payments received up to the date of the certificate.

## **7 Property**

All Materials on the Site, Plant, Equipment, Temporary Works, and Works shall be deemed to be the property of the Procuring Entity if the Contract is terminated because of the Contractor's default.

## **8 Release from Performance**

If the Contract is frustrated by the outbreak of war or by any other event entirely outside the control of either the Procuring Entity or the Contractor, the Project Manager shall certify that the Contract has been frustrated. The Contractor shall make the Site safe and stop work as quickly as possible after receiving this certificate and shall be paid for all work carried out before receiving it and for any work carried out afterwards to which a commitment was made.

**SECTION IX - SPECIAL CONDITIONS OF CONTRACT**

Except where otherwise specified, all Special Conditions of Contract should be filled in by the Procuring Entity prior to issuance of the bidding document. Schedules and reports to be provided by the Procuring Entity should be annexed.

<b>A. General</b>	
<b>GCC 1.1 (r)</b>	The Procuring Entity is <i>[insert name, address, and name of authorized representative]</i> .
<b>GCC 1.1 (v)</b>	The Intended Completion Date for the whole of the Works shall be <i>[insert date]</i> <i>[If different dates are specified for completion of the Works by section (“sectional completion” or milestones), these dates should be listed here]</i>
<b>GCC 1.1 (y)</b>	The Project Manager is <i>[insert name, address, and name of authorized representative]</i> .
<b>GCC 1.1 (aa)</b>	The Site is located at <i>[insert address of Site]</i> and is defined in drawings No. <i>[insert numbers]</i>
<b>GCC 1.1 (dd)</b>	The Start Date shall be <i>[insert date]</i> .
<b>GCC 1.1 (hh)</b>	The Works consist of <i>[insert brief summary, including relationship to other contracts under the Project]</i> .
<b>GCC 2.2</b>	Sectional Completions are: <i>[insert nature and dates, if appropriate]</i>
<b>GCC 5.1</b>	The Project manager <i>[may or maynot]</i> delegate any of his duties and responsibilities.
<b>GCC 8.1</b>	Schedule of other contractors: <i>[insert Schedule of Other Contractors, if appropriate]</i>
<b>GCC 9.1</b>	<p><b>Key Personnel</b></p> <p>9.1 Key Personnel are the Contractor’s personnel named in this GCC 9.1 of the Special Conditions of Contract. The Contractor shall employ the Key Personnel and use the equipment identified in its Bid, to carry out the Works or other personnel and equipment approved by the Project Manager. The Project Manager shall approve any proposed replacement of Key Personnel and equipment only if their relevant qualifications or characteristics are substantially equal to or better than those proposed in the Bid.</p> <p><i>[insert the name/s of each Key Personnel agreed by the Procuring Entity prior to Contract signature.]</i></p>
<b>GCC 13.1</b>	<p>The minimum insurance amounts and deductibles shall be:</p> <p>(a) for loss or damage to the Works, Plant and Materials: <i>[insert amounts]</i>.</p> <p>(b) For loss or damage to Equipment: <i>[insert amounts]</i>.</p> <p>(c) for loss or damage to property (except the Works, Plant, Materials, and Equipment) in connection with Contract <i>[insert amounts]</i>.</p> <p>(d) for personal injury or death:</p> <p>(i) of the Contractor’s employees: <i>[amount]</i>.</p> <p>(ii) of other people: <i>[amount]</i>.</p>

<b>GCC 14.1</b>	Site Data are: <i>[list Site Data]</i>
<b>GCC 20.1</b>	The Site Possession Date(s) shall be: <i>[insert location(s) and date(s)]</i>
<b>GCC 23.1 &amp; GCC 23.2</b>	Appointing Authority for the Adjudicator: <i>[insert name of Authority]</i> .
<b>GCC 24.3</b>	Hourly rate and types of reimbursable expenses to be paid to the Adjudicator: <i>[insert hourly fees and reimbursable expenses]</i> .

#### I B. Time Control

<b>GCC 26.1</b>	The Contractor shall submit for approval a Program for the Works within <i>[number]</i> days from the date of the Letter of Acceptance.
<b>GCC 26.3</b>	The period between Program updates is <i>14</i> days. The amount to be withheld for late submission of an updated Program is <i>[insert amount]</i> .

#### I C. Quality Control

<b>GCC 34.1</b>	The Defects Liability Period is: <i>90</i> days.
---------------------	--

#### I D. Cost Control

<b>GCC 38.7</b>	If the value engineering proposal is approved by the Procuring Entity the amount to be paid to the Contractor shall be <i>_%</i> <i>(insert appropriate percentage. The percentage is normally up to 50%)</i> of the reduction in the Contract Price.
<b>GCC 44.1</b>	The currency of the Procuring Entity's Country is: <i>[insert name of currency of the Procuring Entity's Country]</i> .
<b>GCC 45.1</b>	The Contract <i>[insert "is" or "is not"]</i> subject to price adjustment in accordance with GCC Clause 45, and the following information regarding coefficients <i>[specify "does" or "does not"]</i> apply. <i>[Price adjustment is mandatory for contracts which provide for time of completion exceeding 18 months]</i> The coefficients for adjustment of prices are: (a) <i>[insert percentage]</i> percent nonadjustable element (coefficient A).(ib) <i>[insert percentage]</i> percent adjustable element (coefficient B). (c) The Index I for shall be <i>[insert index]</i> .
<b>GCC 46.1</b>	The proportion of payments retained is: <i>[insert percentage]</i> <i>[The retention amount is usually close to 5 percent and in no case exceeds 10 percent.]</i>

GCC 47.1	<p>The liquidated damages for the whole of the Works are <i>[insert percentage of the final Contract Price]</i> per day. The maximum amount of liquidated damages for the whole of the Works is <i>[insert percentage]</i> of the final Contract Price.</p> <p><i>[Usually, liquidated damages are set between 0.05 percent and 0.10 percent per day, and the total amount is not to exceed between 5 percent and 10 percent of the Contract Price. If Sectional Completion and Damages per Section have been agreed, the latter should be specified here]</i></p>
-------------	--

GCC 48.1	<p>The Bonus for the whole of the Works is <i>[insert percentage of final Contract Price]</i> per day. The maximum amount of Bonus for the whole of the Works is <i>[insert percentage]</i> of the final Contract Price.</p> <p><i>[If early completion would provide benefits to the Procuring Entity, this clause should remain; otherwise delete. The Bonus is usually numerically equal to the liquidated damages.]</i></p>
GCC 49.1	<p>The Advance Payments shall be: <i>[insert amount(s)]</i> and shall be paid to the Contractor no later than <i>[insert date(s)]</i>.</p>
GCC 50.1	<p>The Performance Security amount is <i>[insert amount(s) denominated in the types and proportions of the currencies in which the Contract Price is payable, or in a freely convertible currency acceptable to the Procuring Entity]</i></p> <p>(a) Performance Security - Bank Guarantee: in the amount(s) of <i>[insert related figure(s)]</i> percent of the Accepted Contract Amount and in the same currency(ies) of the Accepted Contract Amount.</p> <p>(b) Performance Security - Performance Bond: in the amount(s) of <i>[insert related figure(s)]</i> percent of the Accepted Contract Amount and in the same currency(ies) of the Accepted Contract Amount.</p>

#### I E. Finishing the Contract

GCC 56.1	<p>The date by which operating and maintenance manuals are required is <i>[insert date]</i>.</p> <p>The date by which "as built" drawings are required is <i>[insert date]</i>.</p>
GCC 56.2	<p>The amount to be withheld for failing to produce "as built" drawings and/or operating and maintenance manuals by the date required in GCC 58.1 is <i>[insert amount in local currency]</i>.</p>
GCC 57.2 (g)	<p>The maximum number of days is: <i>[insert number; consistent with Clause 47.1 on liquidated damages]</i>.</p>
GCC 58.1	<p>The percentage to apply to the value of the work not completed, representing the Procuring Entity's additional cost for completing the Works, is <i>[insert percentage]</i>.</p>

## **FORM No 1: NOTIFICATION OF INTENTION TO AWARD**

This Notification of Intention to Award shall be sent to each Tenderer that submitted a Tender. Send this Notification to the Tenderer's Authorized Representative named in the Tender Information Form on the format below.

-----

### **FORMAT**

1. For the attention of Tenderer's Authorized Representative

- i) Name: *[insert Authorized Representative's name]*
- ii) Address: *[insert Authorized Representative's Address]*
- iii) Telephone: *[insert Authorized Representative's telephone/fax numbers]*
- iv) Email Address: *[insert Authorized Representative's email address]*

*[IMPORTANT: insert the date that this Notification is transmitted to Tenderers. The Notification must be sent to all Tenderers simultaneously. This means on the same date and as close to the same time as possible.]*

2. Date of transmission: *[email]* on *[date]* (local time)

This Notification is sent by *(Name and designation)* \_\_\_\_\_

3. Notification of Intention to Award

- i) Procuring Entity: *[insert the name of the Procuring Entity]*
- ii) Project: *[insert name of project]*
- iii) Contract title: *[insert the name of the contract]*
- iv) Country: *[insert country where ITT is issued]*
- v) ITT No: *[insert ITT reference number from Procurement Plan]*

This Notification of Intention to Award (Notification) notifies you of our decision to award the above contract. The transmission of this Notification begins the Standstill Period. During the Standstill Period, you may:

4. Request a debriefing in relation to the evaluation of your tender

Submit a Procurement-related Complaint in relation to the decision to award the contract.

a) The successful tenderer

i) Name of successful Tender \_\_\_\_\_

ii) Address of the successful Tender \_\_\_\_\_

iii) Contract price of the successful Tender Kenya Shillings \_\_\_\_\_ (in words \_\_\_\_\_)

b) **Other Tenderers**

Names of all Tenderers that submitted a Tender. If the Tender's price was evaluated include the evaluated price as well as the Tender price as read out. For Tenders not evaluated, give one main reason the Tender was unsuccessful.

SNo	Name of Tender	Tender Price as read out	Tender's evaluated price (Note a)	One Reason Why not Evaluated
1				
2				
3				
4				

5. **How to request a debriefing**

- a) DEADLINE: The deadline to request a debriefing expires at midnight on *[insert date]* (local time).
- b) You may request a debriefing in relation to the results of the evaluation of your Tender. If you decide to request a debriefing your written request must be made within three (5) Business Days of receipt of this Notification of Intention to Award.
- c) Provide the contract name, reference number, name of the Tenderer, contact details; and address the request for debriefing as follows:
  - i) Attention: **Fund Account Manager**
  - ii) Title/position: **Fund Account Manager**  
Agency: **Kisumu Central National Government Constituency Development Fund**  
**At DCC Kisumu Central Headquarters**  
Email address: [cdfkisumucentral@ngcdf.go.ke](mailto:cdfkisumucentral@ngcdf.go.ke)
- d) If your request for a debriefing is received within the 3 Days deadline, we will provide the debriefing within five (3) Business Days of receipt of your request. If we are unable to provide the debriefing within this period, the Standstill Period shall be extended by five (3) Days after the date that the debriefing is provided. If this happens, we will notify you and confirm the date that the extended Standstill Period will end.
- e) The debriefing may be in writing, by phone, video conference call or in person. We shall promptly advise you in writing how the debriefing will take place and confirm the date and time.
- f) If the deadline to request a debriefing has expired, you may still request a debriefing. In this case, we will provide the debriefing as soon as practicable, and normally no later than fifteen (15) Days from the date of publication of the Contract Award Notice.

6. **How to make a complaint**

- a) Period: Procurement-related Complaint challenging the decision to award shall be submitted by midnight, *[insert date]* (local time).
- b) Provide the contract name, reference number, name of the Tenderer, contact details; and address the Procurement-related Complaint as follows:
  - i) Attention: **Fund Account Manager**
  - ii) Title/position: **Fund Account Manager**  
Agency: **Kisumu Central National Government Constituency Development Fund**  
**At DCC Kisumu Central Headquarters**  
Email address: [cdfkisumucentral@ngcdf.go.ke](mailto:cdfkisumucentral@ngcdf.go.ke)
- c) At this point in the procurement process, you may submit a Procurement-related Complaint challenging the decision to award the contract. You do not need to have requested, or received, a debriefing before making this complaint. Your complaint must be submitted within the Standstill Period and received by us before the Standstill Period ends.
- d) Further information: For more information refer to the Public Procurement and Disposals Act 2015 and its Regulations available from the Website [info@ppra.go.ke](mailto:info@ppra.go.ke) or [complaints@ppra.go.ke](mailto:complaints@ppra.go.ke).  
You should read these documents before preparing and submitting your complaint.
- e) There are four essential requirements:
  - i) You must be an 'interested party'. In this case, that means a Tenderer who submitted a Tender in this tendering process, and is the recipient of a Notification of Intention to Award.
  - ii) The complaint can only challenge the decision to award the contract.

iii) You must include, in your complaint, all of the information required to support your complaint.

7. Stand still Period

- i) DEADLINE: The Standstill Period is due to end at midnight on *[insert date]* (local time).
- ii) The Standstill Period lasts ten (14) Days after the date of transmission of this Notification of Intention to Award.
- iii) The Standstill Period may be extended as stated in paragraph Section 5 (d) above.

If you have any questions regarding this Notification please do not hesitate to contact us. On behalf of the Procuring Entity:

Signature: \_\_\_\_\_ Name: \_\_\_\_\_

Title/position: \_\_\_\_\_ Telephone: \_\_\_\_\_ Email: \_\_\_\_\_

**FORM NO 2: NOTIFICATION OF AWARD - LETTER OF ACCEPTANCE**

*[letterhead paper of the Procuring Entity] [date]*

To: *[name and address of the Contractor]*

This is to notify you that your Tender dated *[date]* for execution of the *[name of the Contract and identification number, as given in the Contract Data]* for the Accepted Contract Amount *[amount in numbers and words] [name of currency]*, as corrected and modified in accordance with the Instructions to Tenderers, is hereby accepted by *(name of Procuring Entity)*.

You are requested to furnish the Performance Security within 30 days in accordance with the Conditions of Contract, using, for that purpose, one of the Performance Security Forms included in Section VIII, Contract Forms, of the Tender Document.

Authorized Signature: .....

Name and Title of Signatory: .....

Name of Procuring Entity.....

Attachment: *Contract Agreement*.....

**FORM NO 3: CONTRACT AGREEMENT**

THIS AGREEMENT made the \_\_\_\_\_ day of \_\_\_\_\_, 20\_\_\_\_, between \_\_\_\_\_ of \_\_\_\_\_ (hereinafter “the Procuring Entity”), of the one part, and \_\_\_\_\_ of \_\_\_\_\_ (hereinafter “the Contractor”), of the other part:

WHEREAS the Procuring Entity desires that the Works known as \_\_\_\_\_ should be executed by the Contractor, and has accepted a Tender by the Contractor for the execution and completion of these Works and the remedying of any defects therein,

The Procuring Entity and the Contractor agree as follows:

1. In this Agreement words and expressions shall have the same meanings as are respectively assigned to them in the Contract documents referred to.
2. The following documents shall be deemed to form and be read and construed as part of this Agreement. This Agreement shall prevail over all other Contract documents.
  - a) the Letter of Acceptance
  - b) the Letter of Tender
  - c) the addenda Nos \_\_\_\_\_ (if any)
  - d) the Special Conditions of Contract
  - e) the General Conditions of Contract;
  - f) the Specifications
  - g) the Drawings; and
  - h) the completed Schedules and any other documents forming part of the contract.
3. In consideration of the payments to be made by the Procuring Entity to the Contractor as specified in this Agreement, the Contractor hereby covenants with the Procuring Entity to execute the Works and to remedy defects therein in conformity in all respects with the provisions of the Contract.
4. The Procuring Entity hereby covenants to pay the Contractor in consideration of the execution and completion of the Works and the remedying of defects therein, the Contract Price or such other sum as may become payable under the provisions of the Contract at the times and in the manner prescribed by the Contract.

IN WITNESS whereof the parties hereto have caused this Agreement to be executed in accordance with the Laws of Kenya on the day, month and year specified above.

Signed and sealed by \_\_\_\_\_ (for the Procuring Entity)

Signed and sealed by \_\_\_\_\_ (for the Contractor).

**FORM NO. 4 - PERFORMANCE SECURITY**

[Option 1 - Unconditional Demand Bank Guarantee]

[Guarantor letterhead]

**Beneficiary:** \_\_\_\_\_ [insert name and Address of Procuring Entity] **Date:** \_\_\_\_\_

\_\_\_\_\_ [Insert date of issue]

**Guarantor:** [Insert name and address of place of issue, unless indicated in the letterhead]

1. We have been informed that \_\_\_\_\_ (hereinafter called "the Contractor") has entered into Contract No. \_\_\_\_\_ dated \_\_\_\_\_ with (name of Procuring Entity) \_\_\_\_\_ (the Procuring Entity as the Beneficiary), for the execution of \_\_\_\_\_ (Hereinafter called "the Contract").
2. Furthermore, we understand that, according to the conditions of the Contract, a performance guarantee is required.
3. At the request of the Contractor, we as Guarantor, hereby irrevocably undertake to pay the Beneficiary any sum or sums not exceeding in total an amount of \_\_\_\_\_ (in words),<sup>1</sup> such sum being payable in the types and proportions of currencies in which the Contract Price is payable, upon receipt by us of the Beneficiary's complying demand supported by the Beneficiary's statement, whether in the demand itself or in a separate signed document accompanying or identifying the demand, stating that the Applicant is in breach of its obligation(s) under the Contract, without the Beneficiary needing to prove or to show grounds for your demand or the sum specified therein.
4. This guarantee shall expire, no later than the .... Day of ....., 2..<sup>2</sup>, and any demand for payment under it must be received by us at the office indicated above on or before that date.
5. The Guarantor agrees to a one-time extension of this guarantee for a period not to exceed [six months] [one year], in response to the Beneficiary's written request for such extension, such request to be presented to the Guarantor before the expiry of the guarantee."

[Name of Authorized Official, signature(s) and seals/ stamps].

**FORM NO. 6 - ADVANCE PAYMENT SECURITY**

**[Demand Bank Guarantee]**

*[Guarantor letterhead]*

**Beneficiary:** \_\_\_\_\_ *[Insert name and Address of Procuring Entity]*

**Date:** \_\_\_\_\_ *[Insert date of issue]*

**ADVANCE PAYMENT GUARANTEE No.:** \_\_\_\_\_ *[Insert guarantee reference number]* **Guarantor:**

\_\_\_\_\_ *[Insert name and address of place of issue, unless indicated in the letterhead]*

We have been informed that \_\_\_\_\_ (hereinafter called "the Contractor") has entered into Contract No. \_\_\_\_\_ dated \_\_\_\_\_ with the Beneficiary, for the execution of (hereinafter called "the Contract").

Furthermore, we understand that, according to the conditions of the Contract, an advance payment in the sum \_\_\_\_\_ *(in words)* is to be made against an advance payment guarantee.

At the request of the Contractor, we as Guarantor, hereby irrevocably undertake to pay the Beneficiary any sum or sums not exceeding in total an amount of \_\_\_\_\_ *(in words)* \_\_\_\_\_<sup>1</sup> upon receipt by us of the Beneficiary's complying demand supported by the Beneficiary's statement, whether in the demand itself or in a separate signed document accompanying or identifying the demand, stating either that the Applicant:

has used the advance payment for purposes other than the costs of mobilization in respect of the Works; or

has failed to repay the advance payment in accordance with the Contract conditions, specifying the amount which the Applicant has failed to repay.

A demand under this guarantee may be presented as from the presentation to the Guarantor of a certificate from the Beneficiary's bank stating that the advance payment referred to above has been credited to the Contractor on its account number \_\_\_ at \_\_\_.

The maximum amount of this guarantee shall be progressively reduced by the amount of the advance payment repaid by the Contractor as specified in copies of interim statements or payment certificates which shall be presented to us. This guarantee shall expire, at the latest, upon our receipt of a copy of the interim payment certificate indicating that ninety (90) percent of the Accepted Contract Amount, less provisional sums, has been certified for payment, or on the \_\_\_ day of \_\_, 2,<sup>3</sup> whichever is earlier. Consequently, a demand for payment under this guarantee must be received by us at this office on or before that date.

The Guarantor agrees to a one-time extension of this guarantee for a period not to exceed *[six months]* *[one year]*, in response to the Beneficiary's written request for such extension, such request to be presented to the Guarantor before the expiry of the guarantee.

*[Name of Authorized Official, signature(s) and seals/ stamps]*

**FORM NO. 7 - RETENTION MONEY SECURITY**

[Demand Bank Guarantee]

[Guarantor letterhead]

**Beneficiary:** \_\_\_\_\_ [Insert name and Address of Procuring Entity]

**Date:** \_\_\_\_\_ [Insert date of issue]

**Advance payment guarantee no.** [Insert guarantee reference number]

**Guarantor:** [Insert name and address of place of issue, unless indicated in the letterhead]

We have been informed that \_\_\_\_\_ [insert name of Contractor, which in the case of a joint venture shall be the name of the joint venture] (hereinafter called "the Contractor") has entered into Contract No.

\_\_\_\_\_ [insert reference number of the contract] dated \_\_\_\_\_ with \_\_\_\_\_ the Beneficiary, for the execution of \_\_\_\_\_ [insert name of contract and brief description of Works] (hereinafter called "the Contract").

Furthermore, we understand that, according to the conditions of the Contract, the Beneficiary retains moneys up to the limit set forth in the Contract ("the Retention Money"), and that when the Taking-Over Certificate has been issued under the Contract and the first half of the Retention Money has been certified for payment, and payment of [insert the second half of the Retention Money] is to be made against a Retention Money guarantee.

At the request of the Contractor, we, as Guarantor, hereby irrevocably undertake to pay the Beneficiary any sum or sums not exceeding in total an amount of [insert amount in figures] \_\_\_\_\_ ([insert amount in words \_\_\_\_\_])<sup>1</sup> upon receipt by us of the Beneficiary's complying demand supported by the Beneficiary's statement, whether in the demand itself or in a separate signed document accompanying or identifying the demand, stating that the Contractor is in breach of its obligation(s) under the Contract, without your needing to prove or show grounds for your demand or the sum specified therein.

A demand under this guarantee may be presented as from the presentation to the Guarantor of a certificate from the Beneficiary's bank stating that the second half of the Retention Money as referred to above has been credited to the Contractor on its account number at \_\_\_\_\_ [insert name and address of Applicant's bank].

5. This guarantee shall expire no later than the ..... Day of ....., 202...., and any demand for payment under it must be received by us at the office indicated above on or before that date.
6. The Guarantor agrees to a one-time extension of this guarantee for a period not to exceed [six months] [one year], in response to the Beneficiary's written request for such extension, such request to be presented to the Guarantor before the expiry of the guarantee.  
[Name of Authorized Official, signature(s) and seals/ stamps]