

QUOTATION NOTICE



National Government Constituencies Development Fund
MANYATTA CONSTITUENCY
P.O Box 1991-60100
Tel:068-31287 | Cell: 0782055523
Email: cdfmanyatta@ngcdf.go.ke
Website: www.manyatta.cdf.go.ke

10th January 2025

Manyatta NG-CDF invites tenders from interested eligible bidders for the following works:

QUOTATION NO.	QUOTATION DESCRIPTION	ELIGIBILITY	MANDATORY SITE VISIT
NG-CDF/MAN/037/023-024	PHASE 1. CONSTRUCTION OF DINING HALL AT KIRIARI DAY SECONDARY SCHOOL.	Pre-qualified list of suppliers under the category of Building Works – Construction, Repairs and Renovation of GOK buildings for the financial years 2023/2024 and 2024/2025 at NG-CDF Manyatta.	All bidders must attend Mandatory Site Visit on Thursday 14 th JANUARY 2025. Potential bidders will converge at Manyatta NG-CDF office at 9.30am for guidance to the site.

Interested eligible bidders may obtain and inspect tender documents at the Manyatta NG-CDF office during official working hours from Monday to Friday at 9:00am to 5:00Pm or on the NG-CDF website www.ngcdf.go.ke.

Submission shall be done in enclosed plain sealed envelopes marked with the Quotation number and name deposited in the quotation box next to Manyatta NG-CDF offices on or before **17th January, 2025 at 10.00am** and Addressed to:

FUND ACCOUNT MANAGER

**Manyatta National Government Constituency Development Fund.
P.O Box 1991-60100, Embu, cdfmanyatta@ngcdf.go.ke.**

Submitted bids shall be opened at **NG-CDF Manyatta** Board Room **immediately** after the above stated date and time in the presence of tenderers or their representatives who choose to attend. Late bids will not be received.



National Government Constituencies Development Fund
MANYATTA CONSTITUENCY
P.O Box 1991-60100
Tel:068-31287 | Cell: 0782055523
Email: cdfmanyatta@ngcdf.go.ke.
Website: www.manyatta.cdf.go.ke

PHASE 1. CONSTRUCTION OF DINING HALL BLOCK

AT

KIRIARI DAY SECONDARY SCHOOL

QUOTATION NO: NG-CDF/MAN/037/023-024

QUOTATION DOCUMENT

FUND ACCOUNT MANAGER

Manyatta National Government Constituency Development Fund.

P.O Box 1991-60100, Embu, cdfmanyatta@ngcdf.go.ke.

REQUEST FOR QUOTATIONS (RFQ)

INVITATION DATE: 10/01/2025

To:

**FROM: MANYATTA National Government Constituencies Development Fund,
P.O BOX 1991-60100 EMBU**

**FOR PHASE 1. CONSTRUCTION OF DINING HALL AT KIRIARI DAY SECONDARY
SCHOOL**

QUOTATION NO: NG-CDF/MAN/037/023-024

1. P.O BOX 1991-60100 EMBU intends to procure works For **PHASE 1. Construction of Dining Hall at Kiriari Day Secondary School** You have been selected from MANYATTA National Government Constituencies Development fund pre-qualified list of suppliers under the category of Building Works – Construction, Repairs and Renovation of GOK buildings for the financial years 2023/2024 and 2024/2025.
You are required to follow all the instructions as contained in the quotation document. Further information for this quotation may be obtained from the procurement offices during normal working hours.
2. Submission shall be done in enclosed plain sealed envelopes marked with the Quotation number and name deposited in the quotation box next to Manyatta NG-CDF offices on or before **17th January, 2025 at 10.00 Am.**
3. **Preliminary/Mandatory Requirements**
Bidders will be subject to the following mandatory requirements
 - i) Valid current year Tax Compliance
 - ii) Incorporation/registration certificate
 - iii) A valid NCA certificate category 8 and above for building and construction works.
 - iv) A valid annual practicing License for building and construction works
 - v) Attach CR 12 and ID copies of the directors
 - vi) Fill the attached S33 form (Business questionnaire), dated, signed and stamped
 - vii) Fill the attached form of Quotation, dated, signed and stamped
 - viii) Systematic numeric serialization i.e. 1,2,3 etc
 - ix) Completely fill, sign and stamp form for disclosure of interest.Any bidder who will not meet any of the above criteria will be automatically disqualified from further evaluation.
Technical evaluation: The bidders are picked from suppliers' register which means the technical evaluation was done when they were being entered in the register and therefore this step will be skipped for any bidder who meet all the preliminary requirements will automatically proceed to financial evaluation
Financial Evaluation: The lowest evaluated bidder will be awarded if no arithmetic errors.
4. Enquiries regarding this quotation may be addressed to Fund Account Manager, Manyatta National Government Constituencies Development Fund, P.O Box 1991-60100, Embu.
5. Any resulting contract shall be subject to the terms and conditions detailed in Part 2:
6. Please inform by email the undersigned within 5 (five) days of receipt of this RFQ if you will not be submitting a quotation.

CLOSING DATE: 17th January, 2025

TIME: 10.00 Am.

Yours sincerely,

[Fund Account Manager]

PART 1: INSTRUCTIONS TO TENDERERS

1. **Tenderers are advised to read carefully** these instructions and the Conditions of Contract in Part 3 before preparing the quotation. The standard forms in this RFQ may be photocopied for completion but the Tenderer is responsible for their accurate reproduction. The term Tenderer shall mean the firm or person invited to submit a quotation. The term Quotation here in shall mean the quotation submitted as usually understood in public procurement.
2. **Validity of Quotations:** The quotation will be held valid for **90 days** from the date of submission.
3. **Submission of Quotations:** Submission shall be done in enclosed plain sealed envelopes marked with the Quotation name and deposited in the quotation box next to next to Manyatta NG-CDF offices on or **before 17th January, 2025 at 10.00 Am.**
4. **Opening of Quotations:** Quotations will be opened immediately after the closing date and time specified in the quotation document, by at least three appointed officials of the Procuring Entity.
5. **Tenderer Eligibility:** Tenderer must submit Documentary evidence to show His/her eligibility to be awarded a contract to cover all the preliminary requirements stated above. The Tenderer shall also complete attached forms to confirm eligibility and non-existence of a conflict of interest in relation to this procurement requirement by signing the attached Forms.
6. **Invitation not transferable:** This invitation is not transferable to other firms or individuals not so invited.
7. **Currency:** Quotations shall be priced in Kenya Shillings. The Procuring Entity shall not allow quotations in foreign currency.
8. **Evaluation of Quotations:** The evaluation of quotations will be conducted using the procedure set out below:
 - i) Preliminary examination to determine Tenderer eligibility as listed above. Quotations failing this stage will be rejected and not considered in next stage.
 - ii) Technical examination to determine goods eligibility, compliance with technical specifications and commercial responsiveness. The bidders are picked from suppliers' register which means the technical evaluation was done when they were being entered in the register and therefore this step will be skipped for any bidder who meet all the preliminary requirements will automatically proceed to financial evaluation
 - iii) Financial comparison of quotations to determine the lowest evaluated quotation.
9. **Lowest Evaluated Quotation:** The lowest evaluated quotation shall be recommended for award of contract.
10. **Award of contract:** Award of contract shall be by placement of award letter, a Letter of Acceptance or Local Purchase Order: The currency of award and payment shall be in Kenyan

Shilling. Unsuccessful tenderers who responded will be notified of the accepted quotation, indicating the name and the amount of the accepted quotation

11. **Right to Reject:** The Procuring Entity reserves the right to accept or reject any quotation or to cancel the quotation process and reject all quotations at any time prior to contract award.

QUOTATION AND QUALIFICATION DOCUMENTS

Instructions to Tenderer. Tenderer must complete and submit as part of the Form of quotation.

- (i) FORM FOR DISCLOSURE OF INTEREST
- (ii) CERTIFICATE OF INDEPENDENT QUOTATION DETERMINATION
- (iii) SELF-DECLARATION FORM

FORM OF QUOTATION [To be completed by Tenderer]

Quotation Addressed to (Procuring Entity)	MANYATTA NATIONAL GOVERNMENT CONSTITUENCIES DEVELOPMENT FUND
Date of Quotation	
Quotation Reference Number:	
Subject of Quotation	

1. We have examined and have no reservations to the Request for Quotation document, and understand its full content and intent.
2. In compliance with your request for quotations dated:, referenced above, we offer
to.....
..... to cover and conform to our pricing listed in the attached in Table B. Quotation Submission TABLE at a total price of Kenya Shilling
.....(in words) Kshs (In figures)
3. We confirm that we are eligible to participate in public procurement and meet the eligibility criteria specified in Part 1: INSTRUCTIONS TO TENDERERS.

4. We undertake to adhere by the Code of Ethical Conduct for Suppliers during the procurement process and the execution of any resulting contract.
5. We confirm that the prices quoted are fixed and firm for the duration of the validity period and performance of the contract and will not be subject to revision or variation.
6. The validity period of our quotation is: days from the time and date of the submission deadline (*number to be same as in the instructions to Tenderers*).
7. We confirm we are not submitting any other Quotation as an individual or firm, and we are not participating in any other Quotation as a Joint Venture member or as a subcontractor.
8. We, along service providers for any part of the contract, are not subject to, and not controlled by any entity or individual that is subject to a temporary suspension or a debarment imposed by the Public Procurement Regulatory Authority or any other entity of the Government of Kenya, or any international organization.
9. We hereby certify that we have taken steps to ensure that no person acting for us or on our behalf engages in any type of Fraud and Corruption.
10. We hereby certify and confirm that the Quotation is genuine, non-collusive and made with the intention of accepting the contract if awarded. To this effect we have signed the “Certificate of Independent Quotation Determination” attached below.
11. We, the Tenderer, have completed fully and signed the **FORM FOR DISCLOSURE OF INTEREST**- interest of the firm in the Procuring Entity, attached below.

The Delivery period offered is: days from date of acceptance of Quotation. The warranty period offered isweeks.

Quotation Authorized by:

Name:

Designation:

Signature:

Date:

FORM SS3. CONFIDENTIAL BUSINESS QUESTIONNAIRE FORM

You are requested to give the particulars indicated in Part 1 and either Part 2(a), 2(b) or 2 (c) whichever applied to your type of business

You are advised that it is a serious offence to give false information on this form

Part 1 – General:

Business Name

.....

Location of business premises.

.....

Plot No..... Street/Road

.....

Postal Address Tel No. Fax E mail

.....

Nature of Business

.....

Registration Certificate No.

.....

Maximum value of business which you can handle at any one time – Kshs.

.....

Name of your bankers Branch

.....

Part 2 (a) – Sole Proprietor

Your name in full Age

.....

Nationality Country of origin

.....

• Citizenship details

.....

.....

•

Part 2 (b) Partnership Given

details of partners as follows:

Name	Nationality	Citizenship Details
Shares		
1.		
2.		
3.		
..		
4.		

..

Part 2 (c) – Registered Company

Private or Public

.....

State the nominal and issued capital of company-

Nominal Kshs.

Issued Kshs.

Given details of all directors as follows

Name	Nationality	Citizenship Details
------	-------------	---------------------

Shares

1.....

.....

2.

.....

..

3.

.....

4.

.....

5

.....

.

Date Signature of Candidate

.....

- If a Kenya Citizen, indicate under “Citizenship Details” whether by Birth, Naturalization or Registration.

i) **FORM FOR DISCLOSURE OF INTEREST** - Interest of the Firm in the Procuring Entity.

Are there any person/persons in **MANYATTA National Government Constituencies Development fund** who has/have an interest or relationship in this firm? Yes/No.....

If yes, provide details as follows.

	Names of Person	Designation in the Procuring Entity	Interest or Relationship with Tenderer
1			
2			
3			

i) **Conflict of interest disclosure**

	Type of Conflict	Disclosure YES OR NO	If YES provide details of the relationship with Tenderer
1	Tenderer is directly or indirectly controls, is controlled by or is under common control with another tenderer.		
2	Tenderer receives or has received any direct or indirect subsidy from another tenderer.		
3	Tenderer has the same legal representative as another tenderer		
4	Quotation has a relationship with another tenderer, directly or through common third parties, that puts it in a position to influence the quotation of another tenderer, or influence the decisions of the Procuring Entity regarding this quotation process.		
5	Any of the Tenderer's affiliates participated as a consultant in the preparation of the design or technical specifications of the works that are the subject of the quotation.		
6	Tenderer would be providing goods, works, non-consulting services or consulting services during implementation of the contract specified in this Quotation Document.		

7	Tenderer has a close business or family relationship with a professional staff of the Procuring Entity who are directly or indirectly involved in the preparation of the Quotation document or specifications of the Contract, and/or the Quotation evaluation process of such contract.		
	Type of Conflict	Disclosure YES OR NO	If YES provide details of the relationship with Tenderer
8	Tenderer has a close business or family relationship with a professional staff of the Procuring Entity who would be involved in the implementation or supervision of the Contract.		
9	Has the conflict stemming from such relationship stated in item 7 and 8 above been resolved in a manner acceptable to the Procuring Entity throughout the quotation process and execution of the Contract?		

ii) Certification

On behalf of the Tenderer, I certify that the information given above is complete, current and accurate as at the date of submission.

Full Name:

.....
(Signature)

.....
(Date)

iii) CERTIFICATE OF INDEPENDENT QUOTATION DETERMINATION

I, the undersigned, in submitting the accompanying Letter of quotation to the

..... [Name of Procuring Entity] for:

..... [Name and number of quotation] in response to the request for tenders made by:

..... [Name of Tenderer] do hereby make the following statements that I certify to be true and complete in every respect:

I certify, on behalf of [Name of Tenderer] that:

1. I have read and I understand the contents of this Certificate;
2. I understand that the Tenderer will be disqualified if this Certificate is found not to be true and complete in every respect;
3. I am the authorized representative of the Tenderer with authority to sign this Certificate, and to submit the quotation on behalf of the Tenderer;
4. For the purposes of this Certificate and the quotation, I understand that the word “competitor” shall include any individual or organization, other than the Tenderer, whether or not affiliated with the Tenderer, who:
 - a) Has been requested to submit a quotation in response to this request for quotations;
 - b) Could potentially submit a quotation in response to this request for quotations based on their qualifications, abilities or experience;
5. The Tenderer discloses that [check one of the following, as applicable]:
 - a) The Tenderer has arrived at the quotation independently from, and without consultation, communication, agreement or arrangement with, any competitor;
 - b) The Tenderer has entered into consultations, communications, agreements or arrangements with one or more competitors regarding this request for quotations, and the Tenderer discloses, in the attached document(s), complete details thereof, including the names of the competitors and the nature of, and reasons for, such consultations, communications, agreements or arrangements;
6. In particular, without limiting the generality of paragraphs (5)(a) or (5)(b) above, there has been no consultation, communication, agreement or arrangement with any competitor regarding:
 - a) Prices;
 - b) Methods, factors or formulas used to calculate prices;
 - c) The intention or decision to submit, or not to submit, a quotation; or
 - d) The submission of a quotation which does not meet the specifications of the request for quotations; except as specifically disclosed pursuant to paragraph (5) (b) above;
7. In addition, there has been no consultation, communication, agreement or arrangement with any competitor regarding the quality, quantity, specifications or delivery particulars of the supplies to which this request for tenders relates, except as specifically authorized by the procuring authority or as specifically disclosed pursuant to paragraph (5)(b) above;
8. The terms of the quotation have not been, and will not be, knowingly disclosed by the Tenderer, directly or indirectly, to any competitor, prior to the date and time of the official quotation opening, or of the awarding of the Contract, whichever comes first, unless otherwise required by law or as specifically disclosed pursuant to paragraph (5)(b) above.

Name: Title:

Signature: Date:

(Name, title and signature of authorized agent of Tenderer and Date)

iv) SELF-DECLARATION FORM

We, the Tenderer (*insert name*) submitting our Quotation in respect of Quotation No:for (*insert quotation Title Description*) for..... (*insert Name of Procuring Entity*)

DECLARE AS FOLLOWS:

That, We the Tenderer including any entity or individual that directly or indirectly controls, is controlled by or is under common control with us, and any suppliers, consultants, manufacturers, service providers, agents, individuals, or any other party involved or to be involved for any part of the processes of procurement and contract execution related to the above quotation:

a) Have not engaged/will not engage in any corrupt or fraudulent practices in the processes of procurement and contract execution related to the above quotation as defined and/or described in the following:

i). The RFQ for the above Quotation;

ii) Kenya's Public Procurement and Asset Disposal Act, 2015) and its attendant Regulations;

iv) Kenya's Anti-Corruption and Economic Crimes Act, 2013; and

iv) Any such other Acts or Regulations of Government of Kenya;

b) Have not offered/will not offer any inducement to any member of the board, management, staff and/or employees and/or agents of (*name of the procuring entity*);

c) Have not engaged/will not engage in any collusive or corrosive practice with other tenderers participating in the subject quotation;

d) Have not been sanctioned or debarred by any entity from participation in public procurement proceedings of Kenya.

That, what is deponed to herein above is true to the best of our knowledge, information and belief.

Name of the Tenderer: [*Insert complete name of tenderer signing the quotation*]

Name of the person duly authorized to sign the quotation on behalf of the Tenderer:

.....

Title of the person signing the Quotation:

Signature of the person named above:

Date:

PART 3: CONTRACT

CONTRACT AGREEMENT

(1) THIS CONTRACT AGREEMENT is made on day of 20..... Between *[Insert complete name of Procuring Entity]*, and having its principal place of Business at

PART 3: CONTRACT

CONTRACT AGREEMENT

(1) THIS CONTRACT AGREEMENT is made on day of 20..... Between *[Insert complete name of Procuring Entity]*, and having its principal place of Business at *[Insert address of Procuring Entity]* and *[Insert name of Supplier]*, and having its principal place of business at *[Insert address of Supplier]*.

(2) WHEREAS the Procuring Entity invited quotations for the Supply of Goods/ described in Table B, i.e. *[insert brief description of Goods]* and has accepted a Quotation by the Tenderer in the sum of Kenya shillings: *[insert Contract Price in words]* Kshs. *[figures]* (hereinafter called “the Contract Price”).

(3) NOW THIS AGREEMENT WITNESSED AS FOLLOWS:

1. This Contract Agreement includes the following documents:

(a) QUOTATION SUBMISSION TABLE

(b) FORM OF QUOTATION

(c) Conditions of Contract

2. In consideration of the payments to be made by the Procuring Entity to the *Supplier* as hereinafter mentioned, the *Supplier* hereby covenants with the Procuring Entity to provide the Goods and to remedy defects therein in conformity in all respects with the provisions of the Contract.

3. The Procuring Entity hereby covenants to pay the Supplier in consideration of the provision of the Goods and the remedying of defects therein, the Contract Price or such other sum as may become payable under the provisions of the Contract at the times and in the manner prescribed by the Contract.

(4) In WITNESS whereof the parties hereto have caused this Agreement to be executed in accordance with the laws of Kenya.

For and on behalf of the Procuring Entity

Signed:

Designation:

In the presence of:

For and on behalf of the Supplier

Signed:

Designation:

In the presence of:

CONDITIONS OF CONTRACT

1. Language

The Contract as well as all correspondence and documents relating to the Contract exchanged by the Supplier and the Procuring Entity, shall be written in the English Language.

2. Eligibility

The goods shall have the nationality of an eligible country. All Goods to be supplied under the Contract shall have their origin in Eligible Countries.

3. Notices

Any notice given by one party to the other pursuant to the Contract shall be in writing.

4. Governing Law

The Contract shall be governed by and interpreted in accordance with the Laws of Kenya, unless otherwise specified hereunder.

5. Settlement of Disputes

The Procuring Entity and the Supplier shall make every effort to resolve amicably by direct informal negotiation any disagreement or dispute arising between them under or in connection with the Contract. If the parties have failed to resolve their dispute or difference by such mutual consultation, either the Procuring Entity or the Supplier may give notice to the other party of its intention to commence arbitration. The dispute shall be referred to adjudication or arbitration in accordance with the laws of Kenya.

6. Supplier Responsibilities

The Supplier shall supply all the Goods included in the Schedule of Requirements.

7. Contract Price

Prices charged by the Supplier under the Contract shall not vary from the prices quoted by the Supplier and shall be inclusive of all taxes in its quotation.

8. Terms of Payment

The Contract Price shall be paid One hundred (100) percent of the Contract price of goods received upon submission of a claim/invoice supported by the acceptance certificate issued by the Procuring Entity or for Works, upon valuation by the Contractor of the portion of the works completed, such valuation to be accepted by the Procuring Entity, payments up to final completion certificate

9. Inspections and Tests

The Supplier shall at its own expense and at no cost to the Procuring Entity carry out all such tests and/or inspections of the Goods to confirm their conformity to technical specifications.

10. Warranty

The Supplier warrants that all the Goods are new, unused, and of the most recent or current models, and that they incorporate all recent improvements in design and materials, unless provided otherwise in the contract.

BILL OF QUANTITIES FOR

PROPOSED DINING HALL CONSTRUCTION AT KIRIARI DAY SECONDARY SCHOOL

**PREPARED BY:
REGIONAL WORKS OFFICE
STATE DEPARTMENT FOR PUBLIC WORKS
EASTERN REGION
P.O. BOX 455-60100
EMBU.**

OCTOBER, 2024

PROPOSED ADMINISTRATION BLOCK CONSTRUCTION AT KIRIARI DAY SECONDARY SCHOOL

ITEM	DESCRIPTION	QTY	UNIT	RATE	AMOUNT
	<p><u>PRELIMINARIES</u></p> <p>A Allow sum for Branding as directed by the client/ project manager</p> <p>B Allow for Kshs Thirty thousand Kshs 30,000.00 for project documentation.</p> <p>C Allow for Kshs Thirty thousand Kshs 30,000.00 for project management</p>		ITEM		<p>30,000</p> <p>30,000</p>
	TOTAL FOR PRELIMINARIES CARRIED TO GRAND SUMMARY				

PROPOSED ADMINISTRATION BLOCK CONSTRUCTION AT ST. MICHAEL DAY SECONDARY SCHOOL

ITEM	DESCRIPTIONS	QTY	UNIT	RATE	AMOUNT
	<u>ELEMENT NO. 1 -SUBSTRUCTURES</u>				
	<u>(All Provisional)</u>				
	<u>Site Clearance;</u>				
A	Clear the site of all bushes shrubs small trees and burn the arising spoil	335	SM		
B	Allow for keeping foundations free from water, mud, fallen materials.		ITEM		
C	Allow for planking and strutting to sides of all excavations and keeping the same free from fallen materials		ITEM		
	<u>Oversite excavations;</u>				
D	Excavate to remove top vegetable soil not exceeding 1.5metres deep (average 200mm deep) from ground level	335	SM		
	<u>Excavations including maintaining and supporting sides and keeping free from water, mud and fallen material;</u>				
E	Excavate for foundation trenches not exceeding 1.5 metres from stripped levels	68	CM		
F	Ditto to column bases	15	CM		
	<u>Disposal;</u>				
G	Cart away surplus excavated material	28	CM		
H	Return, fill and rum selected excavated material around foundations	55	CM		
	<u>Hardcore or other approved filling, as described;</u>				
I	300mm Thick Approved hardcore well rammed and consolidated under floors to the approval of the Engineer	335	SM		
J	50mm Thick quarry dust blinding	335	SM		
	<i>Carried to Collection</i>				

PROPOSED ADMINISTRATION BLOCK CONSTRUCTION AT ST. MICHAEL DAY SECONDARY SCHOOL

ITEM	DESCRIPTIONS	QTY	UNIT	RATE	AMOUNT
A	<u>Anti-termite treatment;</u> Chemical anti-termite treatment as 'Premise SC 200' or equal and approved, executed complete by an approved specialist under a ten(10) year guarantee to surfaces of hardcore	335	SM		
B	<u>Damp proofing;</u> 500 gauge polythene sheet	335	SM		
C	<u>Concrete Work;</u> 50mm Thick blinding concrete; plain mix 1:4:8 under wall foundations	46	SM		
D	Ditto to column bases	10	SM		
E	<u>Insitu concrete grade 20/20 including vibrating around reinforcement in;</u> Strip footing	9	CM		
F	Ditto to column bases & columns	2	CM		
G	150mm Thick floor slab	335	SM		
	<u>Reinforcement [All Provisional]</u>				
H	<u>High tensile steel reinforcement to B.S 4449 and 4466;</u> Y 12 Bars	225	KG		
I	Y 10 Bars	290	KG		
J	Y 8 Bars	76	KG		
K	Mesh reinforcement ref A142 weighing 2.22 kg per sq. metre in concrete slab including all necessary tying and support (No allowance for laps)	335	SM		
L	<u>Sawn formwork as described to;</u> Sides of strip foundation over 100 mm but not exceeding 200 mm high	30	SM		
M	Ditto to column bases & sub column	49	SM		
N	Edges of floor slab over 75mm but not exceeding 150mm high	76	LM		
	<i>Carried to Collection</i>				

PROPOSED ADMINISTRATION BLOCK CONSTRUCTION AT ST. MICHAEL DAY SECONDARY SCHOOL

ITEM	DESCRIPTIONS	QTY	UNIT	RATE	AMOUNT
A	<p>Walling</p> <p><u>Rough chisel dressed natural stone wall, load bearing 7.0N/mm², bedded and jointed in cement and sand 1:4 mortar reinforced with 25x20 gauge hooped iron at every alternate course as described in;</u></p> <p>150mm Thick walling</p>	105	SM		
	<i>Carried to Collection</i>				
	<p style="text-align: center;"><u>COLLECTION</u></p> <p>From page 1</p> <p>From page 2</p> <p>From above</p>				
TOTAL FOR ELEMENT NO.1 - SUBSTRUCTURES CARRIED TO SUMMARY					

PROPOSED ADMINISTRATION BLOCK CONSTRUCTION AT KIRIARI DAY SECONDARY SCHOOL

ITEM	DESCRIPTION				AMOUNT (KSHS)
	<p><u>PROVISIONAL SUMS</u></p> <p>A Allow for kshs eighty-six thousand and two hundred shillings only Kshs 86,200.00 for project management committee expenses</p>				86,200.00
	PROVISIONAL SUMS CARRIED TO SUMMARY				86,200.00

GRAND SUMMARY

PROPOSED ADMINISTRATION BLOCK CONSTRUCTION AT KIRIARI DAY SECONDARY SCHOOL

ITEM	DESCRIPTION	KSHS	KSHS
		CONTRACTOR'S USE	OFFICIAL USE
1	Preliminaries		
2	BuildersWorks		
3	Provisional Sums	86,200.00	
	SUB-TOTAL(1)		
4	16% ON SUB-TOTAL(1) As Value Added Tax		
	TOTAL CARRIED TO FORM OF TENDER		

Amount in words; *Kenya Shilling*

NAME OF TENDERER.....

ADDRESS.....

SIGNATURE.....STATUS.....

DATE.....

NAME OF WITNESS.....

ADDRESS.....

SIGNATURE.....

DATE.....

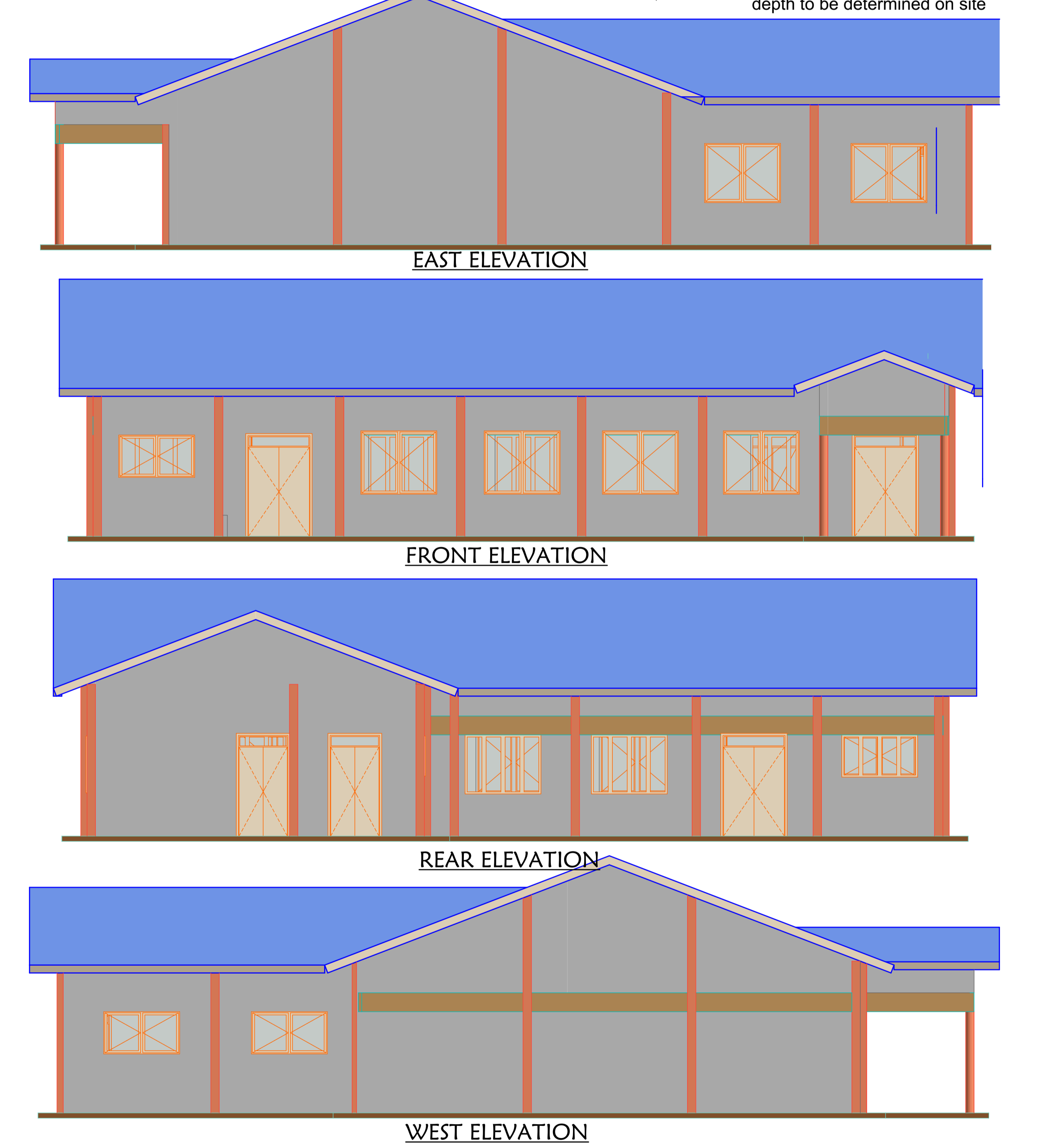
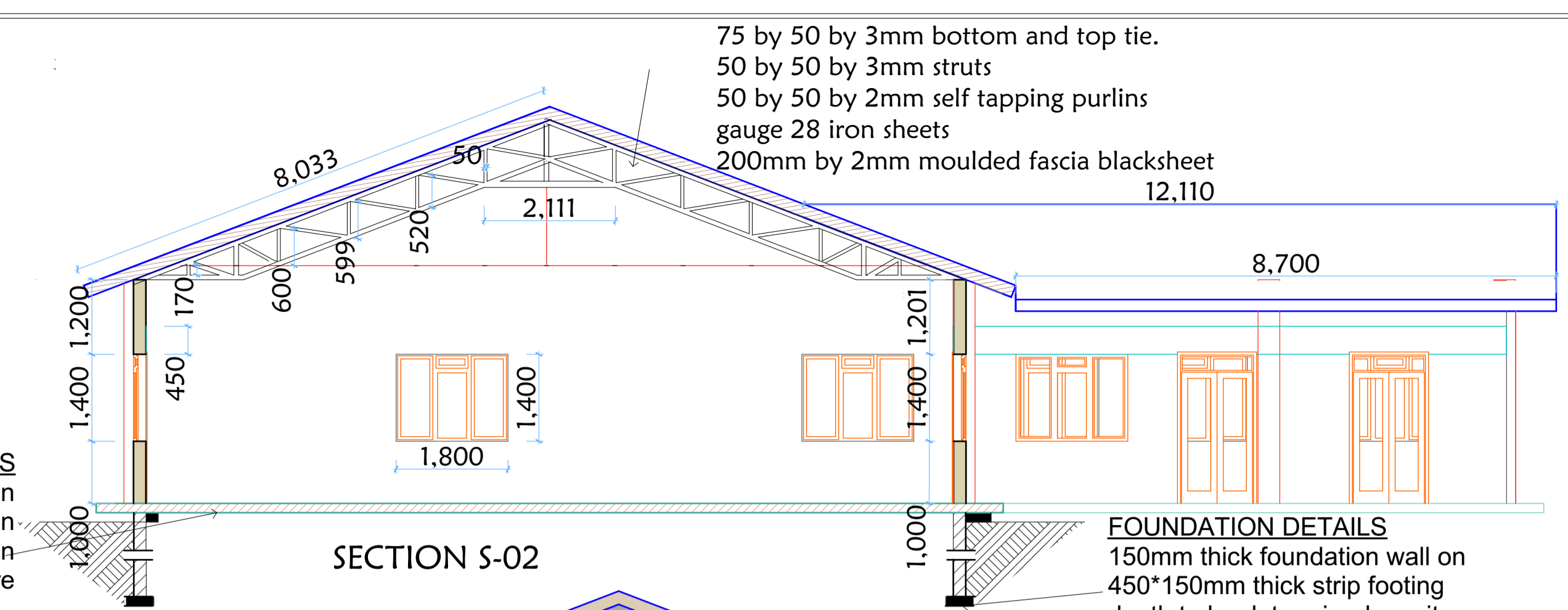
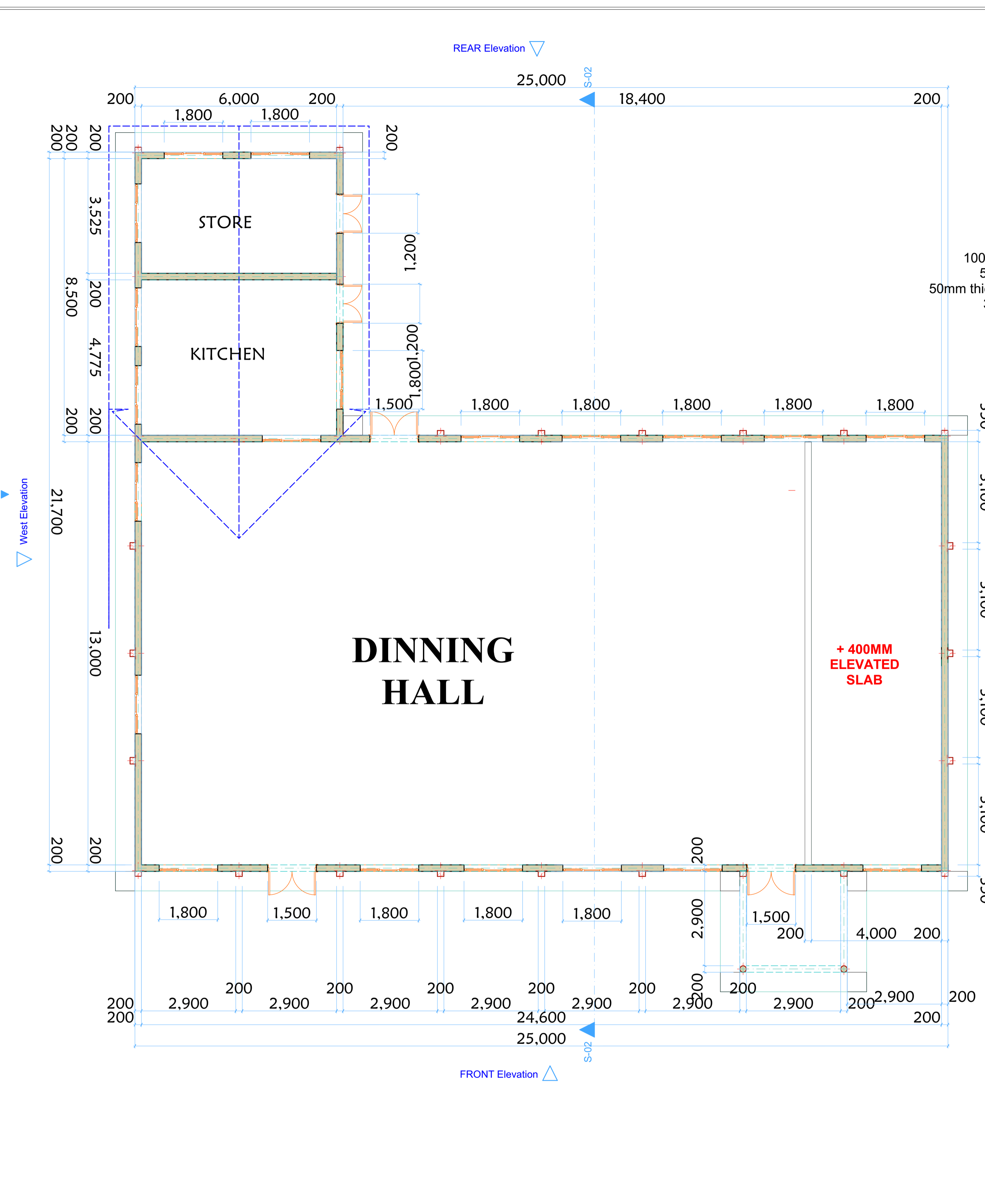

GENERAL
All dimensions are in mm unless otherwise specified. Drawing are not to scaled, only figured dimensions to be used
The contractor must check and verify all demensions before commencement of any work.

CONSTRUCTION
sheet on 50mm thick murrum blinding on hardcore. for termite control.
All slab at ground level to be poured over 1000 guage polythene
All soil under slab around and under foundation to be poisoned
All soil on cut embankment to be stablized. The slope not to exceed the natural angle of repose

STRUCTURAL
All black cotton soil to be removed from all buildings and paved surfaces
For all R.C work, refer to sturctural Engineer's details.
Depth of foundation to be determined on site to S.E.'s aproval
All walls less than 150mm thick to be reinforced with hoop iron at every alternate course.
All adjacent R.C. work and masonry walls to be tied with hoop iron at every alternate course.
All plumbing and drainage to comply with relevant local authority
SVP denotes soil vent pipe to be provided at the head of the drainage system
Drains pass beneath buildings & driveways to be encased in 150mm concrete surround.

The storm drain pipes to comply with BS 556 specification.
All underground foul and waste drain pipes shall be uPVC to comply with BS 5255.
All inspection chambers covers and framing shall be cast iron.
Minimum slope in the drains pipes to be 1 in 100
No chases will be allowed for pipes. Sleeves will be allowed with written aproval of structural Eng's. No cutting of concrete without express aproval of the Architect or structural Eng.
All testing of pipes must be completed before plastering.
All mechnical works must be co-odinated with electrical and any conflict must be clarified be work begin.

FINISHES
All doors and windows to have parmanent ventilations(PV) except w.e's and showers doors.
All floor finishes to be cement/sand screed unless otherwise instructed

REVISIONS

PROJECT TITLE: PROPOSED CONSTRUCTION OF DINING HALL AT KIRIARI DAY SECONDARY SCH.	CLIENT: NG-CDF MANYATTA CONSTITUENCY	STATE DEPARTMENT OF PUBLIC WORKS REGIONAL WORKS OFFICE-EMBU FOR AND ON BEHALF OF THE GOVERNMENT OF THE REPUBLIC OF KENYA		
	DRAWING TITLE: PLANS,ELEVATIONS AND SECTIONS	APPLICATION: ARCHITECTURAL	SIGNATURE:	
		DRAWN BY	E. MWANIKI	SCALES
		DESIGN BY	E. MWANIKI	DATES
		CHECKED BY	N.NGUGI	DRAWING NO: